



**BTN RETURN TRANSMITTER  
INSTRUCTION MANUAL  
AM-MB-RPTDB/SC/302/1**

**INSTRUCTION MANUAL**

Phone: (209) 586-1022

(800) 545-1022

Fax: (209) 586-1026

E-Mail: [salesupport@olsontech.com](mailto:salesupport@olsontech.com)

[www.olsontech.com](http://www.olsontech.com)

## TABLE OF CONTENTS

SAFETY WARNINGS	Page 3
INTRODUCTION	Page 4
INSTALLATION	Page 4
Installation/Environmental Considerations	Page 4
INSTALLATION (cont.)	Page 5
Optical Connectors and Cleaning	Page 5
External Test Points	Page 5
Optical Lid	Page 6

## SAFETY WARNINGS

### LASER RADIATION



The AM-MB-RPTDB/SC/302/1 laser transmitter emits invisible radiation that can cause permanent eye damage. ***AVOID DIRECT EXPOSURE TO BEAM.***



Operate the transmitter only with the proper optical fiber installed in the transmitter optical connector. The power to the AM-MB-RPTDB/SC/302/1 should be turned off whenever the optical connector is opened or exposed (as when the fiber connection is being installed or removed from the transmitter connector).

***NEVER USE ANY OPTICAL INSTRUMENT TO VIEW THE OUTPUT OF THE LASER TRANSMITTER. "OPTICAL INSTRUMENT" INCLUDES MAGNIFYING GLASSES, ETC.***

***NEVER LOOK INTO THE OUTPUT OF THE LASER TRANSMITTER***

***NEVER LOOK INTO THE OUTPUT OF A FIBER CONNECTED TO A LASER TRANSMITTER.***

***NEVER LOOK INTO OR USE ANY OPTICAL INSTRUMENT TO VIEW THE DISTANT END OF A FIBER THAT MAY BE CONNECTED DIRECTLY OR VIA AN OPTICAL SPLIT, TO A TRANSMITTER THAT MAY BE OPERATING. THIS SPECIFICALLY APPLIES TO FIBERS THAT ARE TO BE CONNECTED TO RECEIVERS OR OTHER DEVICES AT ANY DISTANCE FROM THE LASER TRANSMITTER.***

### SHOCK HAZARD

Care should be used when installing the AM-MB-RPTDB/SC/302/1 to prevent shock and injury as there are voltages within the BTN Node which exceed 48 VAC.

## INTRODUCTION

The Olson Technology Inc. AM-MB-RPTDB/SC/302/1 is a high quality, cost effective, Return Transmitter module designed around the latest optical transmitter technology. It is designed to operate and meet full specifications with an optical output level of +3 dBm. The transmitter RF path includes a plug-in OMI pad which is preset at the factory for +40 dBmV carriers. This provides the approved modulation index as reviewed by this customer specific return transmitter variant.

The AM-MB-RPTDB/SC/302/1 receives preconditioned +24 VDC from the BTN Node and plugs directly into the pre-existing optical lid locations within the Node. RF connections and optical fiber routing are provided inside the optical lid of the BTN Node already. Heat transfer for the AM-MB-RPTDB/SC/302/1 is provided via the bottom surface of the module to the existing Node flange for full outdoor temperature operation.

Heat transfer for the AM-MB-RPTDB/SC/302/1 is provided via the bottom surface of the module to the existing Node flange for full outdoor temperature operation.

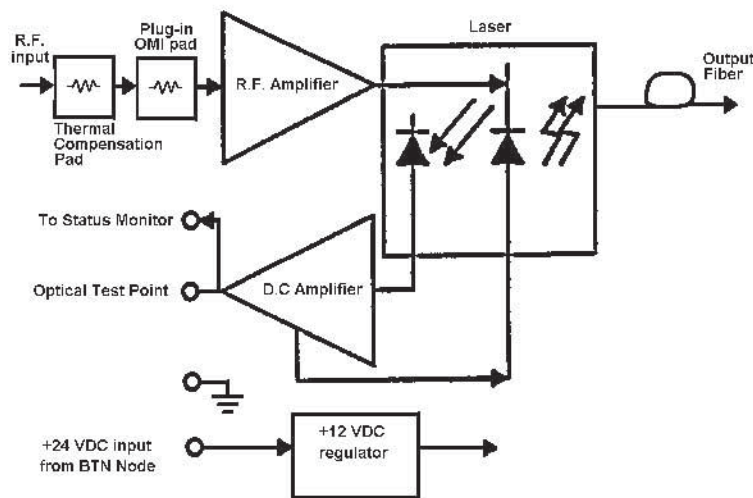

## INSTALLATION / ENVIRONMENTAL CONSIDERATIONS

The AM-MB-RPTDB/SC/302/1 operates with an exterior temperature on the BTN Node of -40 to + 60°C. However, like any other electronic device, it will probably have a longer life span if it is not operated at the upper limit of its temperature range continuously. Installation of the AM-MB-RPTDB/SC/302/1 should be done such that water, dirt and other contaminants do not enter either the Node or the module. Do not install equipment in locations that are accessible by either children or other unqualified personnel. This unit is meant to be field-installed into the Motorola BTN Optical Node by qualified field service technicians.

To install the AM-MB-RPTDB/SC/302/1, loosen the 5 of 8 closure bolts on the BTN Node casting enough to rotate the seizure mechanisms off of the lid of the housing. Open the housing and locate the optical lid as the half clam-shell with the optical connectors in it. Place the AM-MB-RPTDB/SC/302/1 module into one of the 2 center locations above the back plane, making sure to orient the 4 position connector on the bottom of the AM-MB-RPTDB/SC/302/1 module in line with the mating connector on the back plane. Push the AM-MB-RPTDB/SC/302/1 into position firmly, seating the connector. Tighten the 2 captive bolts. Connect the coaxial RF input cable from the transmitter to an F-81C adapter in the housing lid that is already connected to one of the return output ports on the forward-return motherboard. Connect the fiber pigtail from the transmitter to a spare optical bulkhead adapter, then dress the fiber into the fiber spool tray in the lid of the housing. Make adjustments to the RF cable and fiber as necessary. Carefully close the housing lid while preventing cables and fibers from being pinched. Rotate the seizures onto the housing lid and tighten the closure bolts per the Motorola specification.

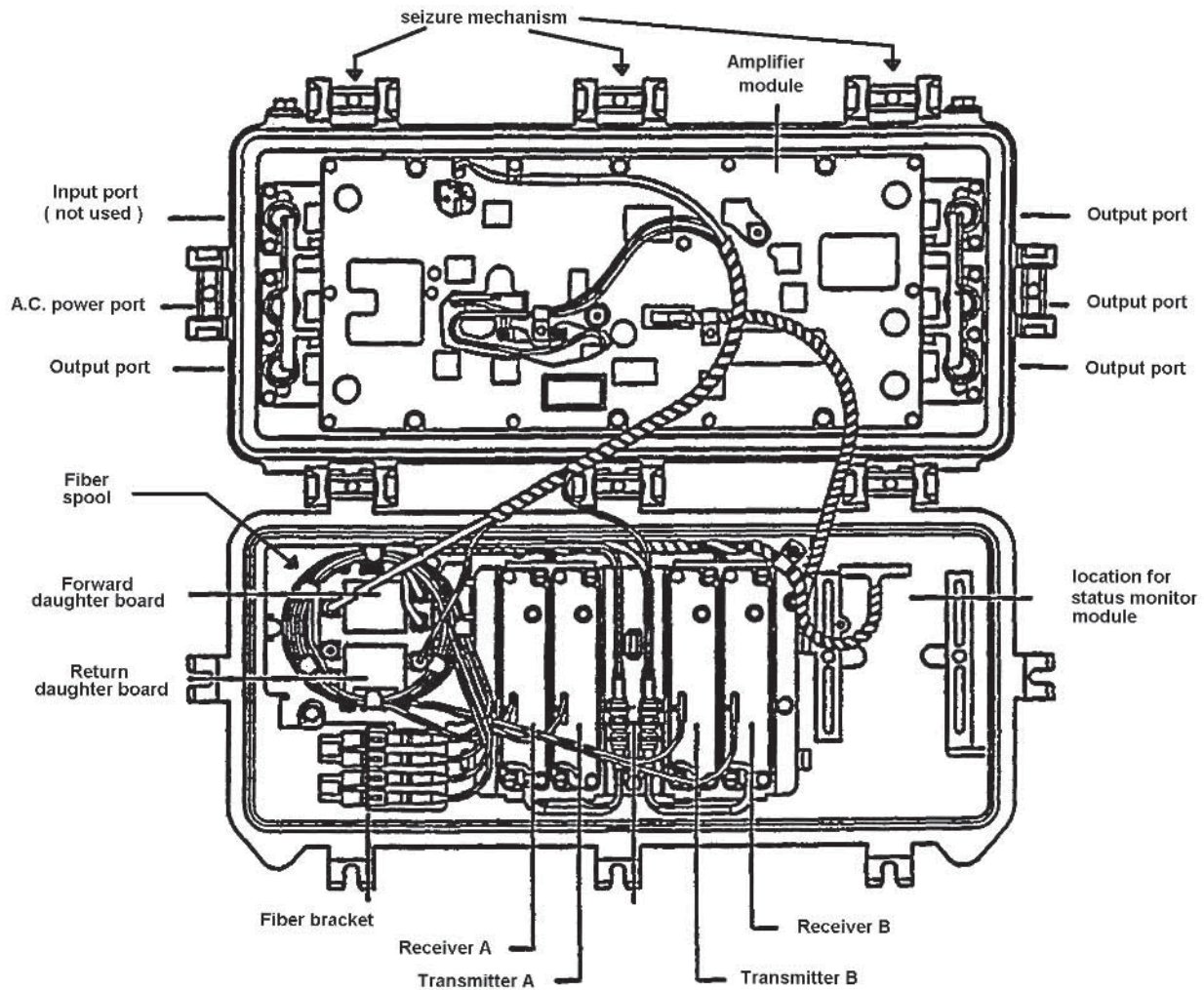

## OPTICAL CONNECTORS AND CLEANING

The standard optical connector provided with the AM-MB-RPTDB/SC/302/1 is an SC/APC with an 8° angle. No tools are required for connection to/from this type of optical connector.

The fiber ends can be damaged by the insertion of contaminated connectors into a bulkhead or receptacle, or by the insertion of a clean connector into a dirty bulkhead. Fiber connectors should never be left uncovered. Optical connectors should be cleaned before usage. Prepackaged alcohol wipes are the most convenient way to insure clean optical connectors. Fresh, clean alcohol and lint free wipes or swabs may also be used.

## EXTERNAL TEST POINTS

The AM-MB-RPTDB/SC/302/1 has 1 external test point for optical power output calibrated at 10V/mW. It should be monitored with a high impedance voltmeter. This test point is for long term monitoring purposes. The optical output power should be measured using an optical power meter at the time of installation.

