



Model OT-1000-HH

1GHz SuperMod Optical Transmitter, DWDM



BASIC OPERATING MANUAL

Some of the features mentioned in this Basic OT-1000-HH Manual can only be accessed with the optional OT-NEC-A, Network Element Controller. These features are noted with a “*” after the section titles. Refer to the Advanced OT-1000-HH Manual for a detailed understanding of these features.***

24926 Highway 108
Sierra Village, CA 95346
Phone: (800) 545-1022
Fax: (209) 586-1022

TABLE OF CONTENTS

SAFETY	3
Safety Precautions	3
Laser Safety Procedure	3
General Safety Instructions	4
Laser Safety Instructions	4
GENERAL DESCRIPTION	7
Figure 1 - Transmitter Front Panel	7
PRINCIPLES OF OPERATION	7
Figure 2 - Block Diagram of OT-1000-HH	7
Principle of Element Management	9
Figure 3 - The OT-1000-HH interfacing with other equipment and a SNMP EMS.	9
Technical Specifications	10
Features	10
Optical Properties	11
Electrical Properties	11
Test Configurations	11
Operating the OT-1000-HH	12
Handling Optical Components	12
Installing the OT-1000-HH	14
Figure 4 - Rear of OT-1000-HH	14
Power-Up Sequence	15
Setting Appropriate Operating Conditions	15
Redundancy Applications (Optical Power On /Off)	18
LED Display and Alarms	19

SAFETY

Safety Precautions

The optical emissions from the units are laser-based and may present eye hazards if improperly used. **NEVER USE ANY KIND OF OPTICAL INSTRUMENT TO VIEW THE OPTICAL OUTPUT OF THE UNIT.** Be careful when working with optical fibers. Fibers can cause painful injury if they penetrate the skin.

Laser Safety Procedure

ALWAYS read the product data sheet and the laser safety label before powering the product. Note the operation wavelength, optical output power and safety classifications.

If safety goggles or other eye protection are used, be certain that the protection is effective at the wavelength emitted by the device under test BEFORE applying power.

ALWAYS connect a fiber to the output of the device BEFORE power is applied. Power should never be applied without an attached fiber. If the device has a connector output, a connector should be attached that is connected to a fiber. This will ensure that all light is confined within the fiber waveguide, virtually eliminating all potential hazards.

NEVER look at the end of the fiber to see if light is coming out. NEVER! Most fiber optic laser wavelengths (1310nm and 1550nm) are totally invisible to the unaided eye and will cause permanent damage. Always use instruments, such as an optical power meter, to verify light output.

NEVER, NEVER, NEVER look into the end of a fiber on a powered device with ANY sort of magnifying device. This includes microscopes, eye loupes and magnifying glasses. This WILL cause a permanent and irreversible burn on your retina. Always double check that power is disconnected before using such devices. If possible, completely disconnect the unit from any power source.

If you have questions about laser safety procedures, please call Olson Technology before powering your product.

Attention:
Please read the instructions completely and carefully before putting the unit into operation!
All operation steps should be carried out in the prescribed sequence!
Improper putting into operation can cause serious danger for personnel and/or damage the device.

**INVISIBLE LASER RADIATION
DO NOT STARE INTO BEAM OR VIEW DIRECTLY
WITH OPTICAL INSTRUMENTS
CLASS 1M LASER PRODUCT
MAXIMUM OUTPUT POWER: 150mW
WAVELENGTH: 1550nm
IEC 60825-1 (08/2001)**

NOTICE

Read this chapter containing safety instructions before operating the system for the first time or carrying out any modifications to the transmitter. It is also recommended to re-read the chapter at certain intervals in order to refresh your knowledge about safety.



The transmitter may only be operated by personnel who have received the necessary training in handling optical and electrical equipment and have been instructed in laser safety.

General Safety Instructions



Please read all instructions completely and carefully before putting into operation! All operation steps should be carried out in the prescribed sequence! Improper putting into operation can cause death or serious physical harm of persons or damage the devices.

NOTICE

Operational Personnel
The transmitter OT-1000-HH may only be operated by personnel who have received the necessary training in handling optical and electrical equipment and have been instructed in laser safety.



Module Locations
The transmitter shall only be operated in locations with restricted access.

Laser Safety Instructions



Laser Equipment
Module operation and maintenance must only be carried out by persons who have received adequate training in laser safety.
The optical transmitters and amplifiers used in the system emit optical power in the **invisible** infrared spectrum range. Under normal operating conditions, the optical

power is transferred in the fibers and is not accessible. Each optical transmitter and each optical amplifier is assigned to a hazard level according to IEC 60825–2. This hazard level is based on radiation that could become accessible under reasonable foreseeable circumstances, e.g. disconnected fiber connector, fiber cable break.

NOTICE

Hazard Level

The hazard level of the optical transmitter is: **1M: eye safe for normal viewing** (without optical aids).

Where possible, optical transmission or test equipment should be shut down, put into a low power state of disconnected before any work is completed on exposed fiber, connectors, etc.

Check optical power in a fiber using a calibrated optical power meter.

If it is necessary to look at fibers or connectors: Ensure that the fibers do not transmit optical power. Therefore, use a calibrated optical power meter.

Do not stare directly into the beam and do not use any unapproved collimating device to view the fiber ends or connector faces. Always use approved eye protection equipment if hazardous level requires. Do not point fiber ends at other people.

If the work to be carried out requires the use of eye protection, only use equipment which has been tested and approved for the wavelengths involved.

Any single or multiple fiber ends or ends found not to be terminated with power levels exceeding hazard level 1 should be individually or collectively covered when not being worked on. Use only covers or covering material with sufficient attenuation of the optical power at the wavelength concerned. Sharp ends should not be exposed.

When using optical test cords, the optical power source shall be the last to be connected and the first to be disconnected.

Do not make any unauthorized modifications to any optical fiber system or associated equipment.

Replace damaged optical safety labels or attach new labels if labels are missing.

Use test equipment of the lowest class necessary and practical for the task. Do not use test equipment of a higher class than the location hazard level.

INTRODUCTION

The OT-1000-HH transmitter is a highly sophisticated Direct Modulation 1550nm Fiber Optic CATV Transmitter. Its performance rivals that of the world's best External Modulation 1550nm Fiber Optic CATV Transmitters at distances up to 20km. Because of its unmatched level of performance, we refer to the OT-1000-HH as a "SuperMod" transmitter. The basic OT-1000-HH transmitter is configured by Olson personnel to have the most common settings and features enabled. Olson also presets the dispersion compensation distance to a value from 0km to 20km according to the detailed part number provided by the customer. It is possible for the customer to access a wide array of internal features by means of a Network Element Controller, such as the Olson OT-NEC-A, sold separately. Since most customer's needs are met by the basic transmitter, the Operating Manual is broken down into two parts. There is a Basic manual describing the installation and operation of the stand-alone transmitter. A second manual, describes Advanced topics dealing mainly with features that can only be accessed with the OT-NEC-A, Network Element Controller. Some of the features that can only be used with the optional Network Element Controller, are briefly mentioned in the Basic manual. These features are noted with a "***".

This document contains the description for the base units OT-1000-HHcxx (19" wide housing). The OT-1000-HH is intended for CATV broadcast applications with a typical frequency range from 47 to 1,000MHz and analog and/or digital modulation scheme

The extension c (in OT-1000-HHcxx) specifies the frequency plan such as "C" for CENELEC42 (European), "B" for German KDG/T-Systems (PAL) and "N" for NTSC (US/Japanese)

The wavelength (xx) is specified based on wavelength or ITU grid channel number.

ITU Channel No.	DWDM Frequency	DWDM Wavelength
22	192.2THz	1559.79nm
23	192.3THz	1558.98nm
24	192.4THz	1558.17nm
25	192.5THz	1557.36nm
26	192.6THz	1556.55nm
27	192.7THz	1555.75nm
28	192.8THz	1554.94nm
29	192.9THz	1554.13nm
30	193.0THz	1553.33nm
31	193.1THz	1552.52nm
32	193.2THz	1551.72nm
33	193.3THz	1550.92nm
34	193.4THz	1550.12nm
35	193.5THz	1549.32nm
36	193.6THz	1548.51nm
37	193.7THz	1547.72nm
38	193.8THz	1546.92nm
39	193.9THz	1546.12nm
40	194.0THz	1545.32nm
41	194.1THz	1544.53nm
42	194.2THz	1543.73nm
43	194.3THz	1542.94nm
44	194.4THz	1542.14nm
45	194.5THz	1541.35nm
46	194.6THz	1540.56nm

GENERAL DESCRIPTION

The optical transmitter represents a family of directly-modulated DFB laser transmitters. These products have been developed to fulfill the requirements of modern HFC (hybrid fiber coax) networks for the transmission of CATV (cable television), cable phone and cable data signals.

The optical transmitter comes in a stand-alone housing to be mounted in 19" EIA racks. Optical and RF connections are performed from the module front. In this housing, the module is directly powered by 110/230V_{AC}. Powering and management interface is available at the rear.



Figure 1 — Transmitter Front Panel

PRINCIPLES OF OPERATION

Model OT-1000-HH - Block Diagram

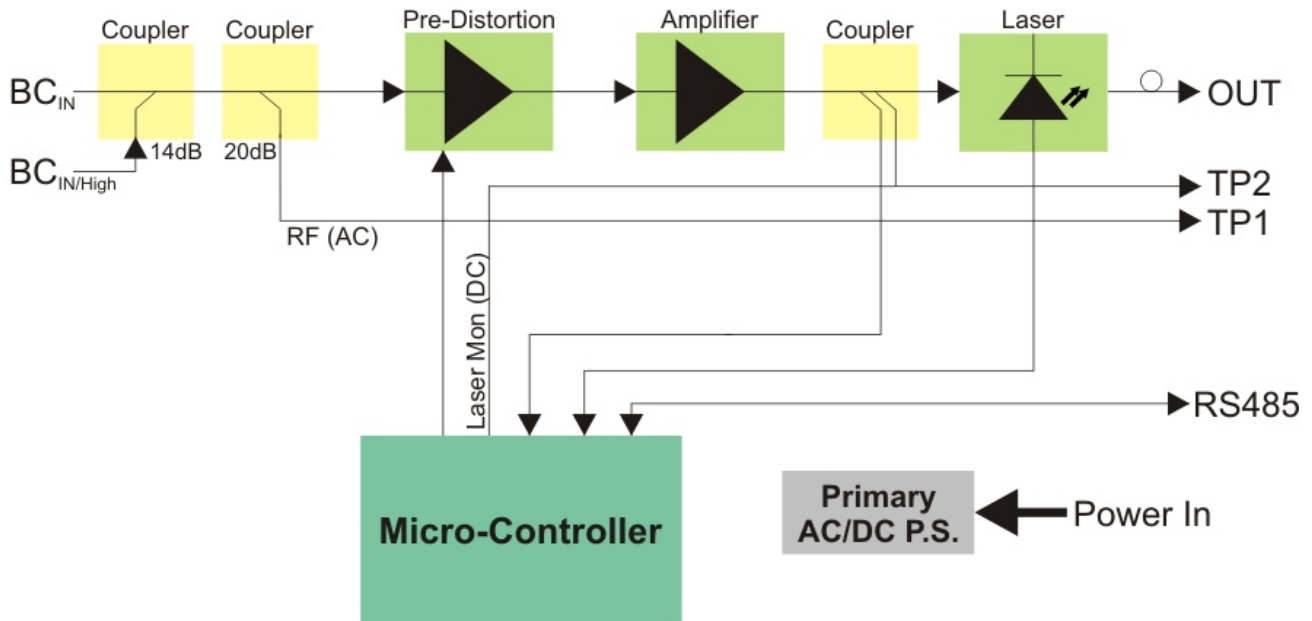

Figure 2 — Block Diagram of OT-1000-HH

The OT-1000-HH is equipped with state-of-the-art microprocessor circuitry supporting electronic adjustments, without switches, gain controls, or buttons.

The transmitter offers two RF inputs, allowing easy combining of broadcast (BC) and narrowcast (NC) signals:

- A low level RF signal input, generally dedicated to broadcast signals in downstream applications, and
- A high-level RF signal input, generally dedicated to narrowcast signals in downstream applications. The high-level input requires a 14 dB higher RF input level in order to obtain the same OMI (optical modulation index) as on the low-level input.

Test point TP1 is the output of a directional coupler, allowing the operator to measure and supervise the combined RF input signal available with a level of -20dB related to the “low” input or -6dB related to the “high” input.

Additionally a laser driver test point (TP2) is available, allowing the user to measure:

- The optical output power of the transmitter simply by measuring a DC voltage, which is proportional to the actual optical DC power in mW. (0.1Volts = 1mW)
- The optical modulation index (OMI), by measuring the RF level at the test-point. An RF level of +20dBmV corresponds to 5% (peak) optical modulation index at nominal optical output power.

A general-purpose amplifier including laser pre-distortion and laser pre-chirping technology follows the directional coupler. This amplifier features:

- Variable gain adjustment
- Variable slope adjustment

The microprocessor (μ P) uses the detected RF signal at the laser to establish an automatic load control (ALC) of the laser driver, thus preventing under- or over-modulation of the laser.

The cooled laser versions are equipped with a thermoelectric cooler in on order to achieve a stable transmission and wavelength performance.

The OT-1000-HH offers the possibility to fine-tune the optical wavelength of the laser optical frequency by ± 100 GHz in steps of 50GHz for DWDM operation. Additionally the OT-1000-HH transmitter supports SBS suppression technology for a SBS threshold of up to +15dBm. Laser pre-chirping technology is implemented to optimize the transmission performance for a distinct transmission distance. An electronic compensation circuitry reduces the impact of dispersion on the transmission performance especially regarding CSO.

Principle of Element Management ***

Advanced features of the OT-1000-HH can be accessed through a network element controller, such as the Olson OT-NEC-A via the RS485 interface. The OT-NEC-A polls the OT-1000-HH as well as many other connected devices and provides an Ethernet interface for easy connections to a network management system (NMS) or personal computer (PC). The operation of these features is covered in the ADVANCED OPERATION MANUAL for the OT-1000-HH.

The picture below explains how the OT-1000-HH interfaces to other devices and a SNMP EMS.

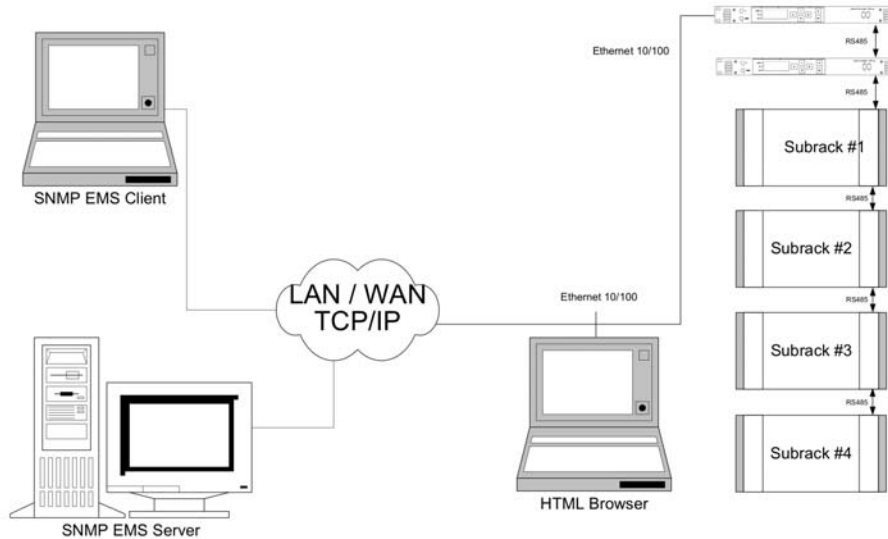

Figure 3 — The OT-1000-HH interfacing with other equipment and a SNMP EMS.

All of these connected devices only provide RS-485 slave interfaces, since the NEC is the dedicated RS-485 bus master, polling all other devices. This embedded NEC, which is in fact a proxy agent, polls all devices and translates this information to Ethernet-HTTP and Ethernet-SNMP.

In the example, there is a PC (e.g., notebook) with an HTML browser (such as Microsoft Internet Explorer, Netscape, Mozilla or Opera). If the browser accesses the IP address of the NEC, which can be set in order to fit to the requirements of a LAN, the web server software running on the NEC responds and displays information of all polled devices on the browser screen. Using the PC, it is possible to get access to the data of all devices as well as to change settings of all the devices.

Simultaneously, in the example there is optionally an SNMP EMS (Element Management System) connected to the Ethernet interface. This connection can be realized using a LAN or a WAN between the EMS and the OT-1000-HH. This EMS corresponds with the NEC using SNMP (simple network management protocol).

The NEC supports at the same time HTTP and SNMP on the Ethernet interface. The EMS can be implemented to enable a more sophisticated alarm management with alarm filtering, alarm acknowledgement and automatic messaging through e-mails or SMS etc.

See the ADVANCED OPERATION MANUAL for the OT-1000-HH for a detailed of how these SNMP features operate.

TECHNICAL SPECIFICATIONS

Features

- Low noise DFB laser with pre-distortion technology
- Optical output power of +8dBm
- Ultra broad bandwidth of 47 to 1,000MHz
- Dual RF inputs for broadcast and narrowcast input
- Dual RF test points for RF input and laser driver
- Automatic load control (ALC)
- SBS suppression and pre-chirping technology
- Adjustable ITU grid wavelength
- All-electronically adjustments for slope, gain, output power, OMI, pre-chirping etc.
- Powerful element management features

Parameter	Unit	Min.	Typ.	Max.	Remark
Optical connector		SC/APC			
Nom. RF input level (low input) Nom. RF input level (high input)	dBmV		+20 +34		OMI=5%, per TV carrier
Min. RF input level (low input) Min. RF input level (high input)	dBmV		+13 +27		OMI=5%, per TV carrier
RF gain	dB	-17		+7	Referred to nom. input level
TP1 Attenuation	dB	19 18.5	20 20	21 21.5	47 ... 606MHz 606 ... 1,000MHz
TP2 RF level	dBmV	+18	+20	+22	Referred to OMI=5%
TP2 DC level	V/mW	0.08	0.1	0.12	
RF slope range (cable equivalent ... cable equalization)	dB	-3		+16	Referred to 47 and 862MHz
RF return loss (referred to 75Ω)	dB	18			> 20 (@47MHz) – 1.5dB/oct., min. > 15 (47 ... 1,000MHz)
Pilot tone frequency	kHz		614		(307 also software adjustable)
Equipment operation environmental conditions		Class 3.1 according ETS 3 019-1-3, but module temperature is restricted to -5 ... +45°C			
Laser safety		Hazard level 1M according to IEC60825 ("eye-safe" for normal viewing)			
Product safety		EN583-1, EN60950			
EMC		EN583-2			
Power Supply Voltage	V _{AC}	100		240	
Power consumption	W			17	
Weight	Kg		2		

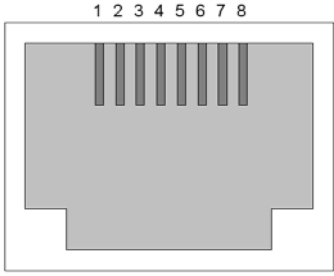
Parameter	Unit	Min.	Typ.	Max.	Remark
Network Management Interface					Two RJ45 connectors for RS-485 bus implementation: Pin 1: RS-485 + Pin 2: RS-485 - Pin 3: Not used Pin 4: Not used Pin 5: Not used Pin 6: Not used Pin 7: Not used, opt. +24 V _{DC} Pin 8: GND Case: GND

Optical Properties

Parameter	Unit	Value
Wavelength	nm	ITU DWDM channel
Wavelength tuning range	GHz	± 100
Wavelength tolerance (for full temperature range)	nm	± 0.07
Laser type		cooled DFB laser with optical isolator
Optical power	dBm	8
Optical power tolerance	dB	± 1.0
Optical power adjustment range	dB	0 ... -3
Optical return loss	dB	> 45
RIN (opt. return loss < -40 dB)	dBc/Hz	< -154

Typical Electrical Properties

Parameter	Unit	Value		
RF-Frequency Range	MHz	47 - 1,000		
Flatness	dB	<±0.5 @ 47 ... 606MHz <±0.75 @ 47 ... 862MHz <±1.5 @ 47 ... 1,000MHz		
Version "c"		C	B	N
Channel plan		CENELEC 42	PAL-B/G	NTSC 77
number of channels TV / FM (-4dB) / QAM64 (-10dB)		42 / 0 / 0	36 / 0 / 0	74 / 0 / 0
OMI	%	4.1	4.1	4.1
Noise bandwidth	MHz	5.0	5.0	5.0
CNR Tx/Rx	dB	53	53	53
CNR Link 1	dB	51	51	51
CSO Tx/Rx (pre-chirping adjusted to 10 km)	dBc	56 60 (< 6 MHz)	56 60 (< 6 MHz)	56 60 (< 6 MHz)
CSO and Link 1 (pre-chirping adjusted to 10 km)	dBc	50 56 (< 6 MHz)	50 56 (< 6 MHz)	50 56 (< 6 MHz)
CTB	dBc	62	62	62

Test Configurations

Configuration	Booster EDFA	Fiber Length	Rx
---------------	--------------	--------------	----

Tx/Rx *)	no	No	0dBm
Link 1 *)	no	20 km	0dBm

* Rx with 7pA/√Hz input noise current density, Standard, non dispersion shifted fiber according to ITU-T G.652, RF input level at +20dBmV per TV channel

OPERATING THE OT-1000-HH

Handling Optical Components

Handling Optical Fibers

The smallest permissible bending radius for fibers used to connect optical HFC modules is 30mm (diameter of 60mm). A smaller radius significantly increases attenuation of the fiber optic cables and may even damage the fibers. Therefore, handle the fibers carefully, especially during installation.

Connecting and Disconnecting Optical Connectors

Please proceed as follows for connecting optical links:

- 1) Loosen the dust caps from the transmitter's optical port (1) and fiber patch cord.
- 2) Note the orientation of the module's optical connector (2). Plug the optical male connector of the patch into the female connector of the module.
- 3) Save the dust caps.

Please proceed in the reverse order for disconnecting optical links.



Do not stare into the laser beam of view directly with optical instruments!

In order to prevent uncontrolled emission of laser beams, close the optical line connector immediately after opening the connection, using the dust caps designed for this purpose.

Cleaning Optical Connections

When a connector has been connected and disconnected several times, it may be necessary to clean the connector thoroughly. Suggested cleaning agents include:

- Cleaning cloths made of lint-free, disposable paper (Kimwipes from Kimberly-Clark)
- Cleaning fluid: Isopropyl alcohol min. 99%
- Compressed air



Laser Radiation

If you inspect the front of the plug when the equipment is switched on, there is a danger of damage to your eyes.

Therefore, always switch the equipment off for this kind of work. Use a measuring device to ensure that there is no laser beam emission from the fiber.

NOTICE

Do not touch the surface with your fingers when cleaning.

Plug pins with imprinted grooves on the front must only be daubed clean using a brush.

Dust or fluff can be blown away using the rubber bellows or dust-free compressed air.

Cleaning the plug pins

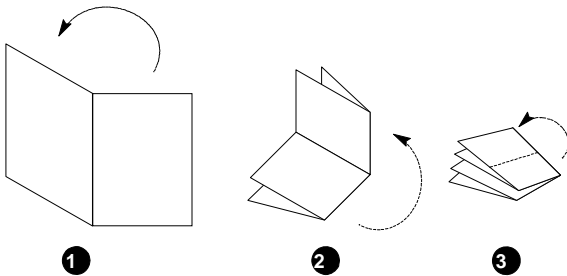

- 1) Fold the cleaning cloth three times. The cloth pad now constitutes an eight-layered cloth.

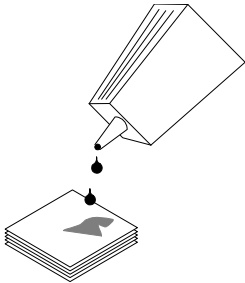

- 2) Moisten the folded cloth a little using the cleaning fluid, ensuring that a dry area remains.

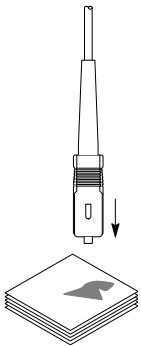

- 3) Place the front surface of the connector, or the connector shaft on the moistened part of the cloth, pressing lightly. Let the cleaning fluid work into the dirt for a short time.

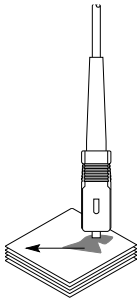

- 4) Move the connector back and forth on the moistened part of the cloth, turning slightly and pressing lightly. Slide the front surface of the connector, or connector shaft, from the moist to the dry area, without breaking the surface contact with the cloth, so that no cleaning agent residue is left.

NOTICE

If the result of cleaning is not good, repeat the procedure.

- 5) Reconnect the connector or cover it immediately with a dust cap.

Installing the OT-1000-HH

Please follow these instructions for correctly installing the transmitter module OT-1000-HH:

- 1) The OT-1000-HH is intended for mounting in 19-in EIA equipment racks.
- 2) Please observe rack safety (refer to rack vendor manuals).
Mount the chassis according to rack vendor requirements. Do not forget to use the grounding screw if required. Connect power supply on the module's rear with delivered powering cable only. Do not use other powering cable from third-party vendors! Connect module RF and optical connections.
- 3) Be sure that the OT-1000-HH is going to be put into operation under the specified environmental conditions. Avoid temperature shocks after transportation of the module and allow sufficient time to accommodate with the environmental conditions at the operating site. Switch on the module at the rear power switch. After start, the "Module" LED on the front will light Green and the other LED's should monitor the status of the transmitter.
- 4) It is possible to connect the transmitter to an Olson network management controller OT-NEC-A by the rear RS-485 interface. Typical (Ethernet) RJ45 cable connects the OT-NEC-A and the OT-1000-HH to establish the RS-485 management bus. The pin out of the RJ45 cable is shown on page 11.
- 5) Set appropriate operating conditions.

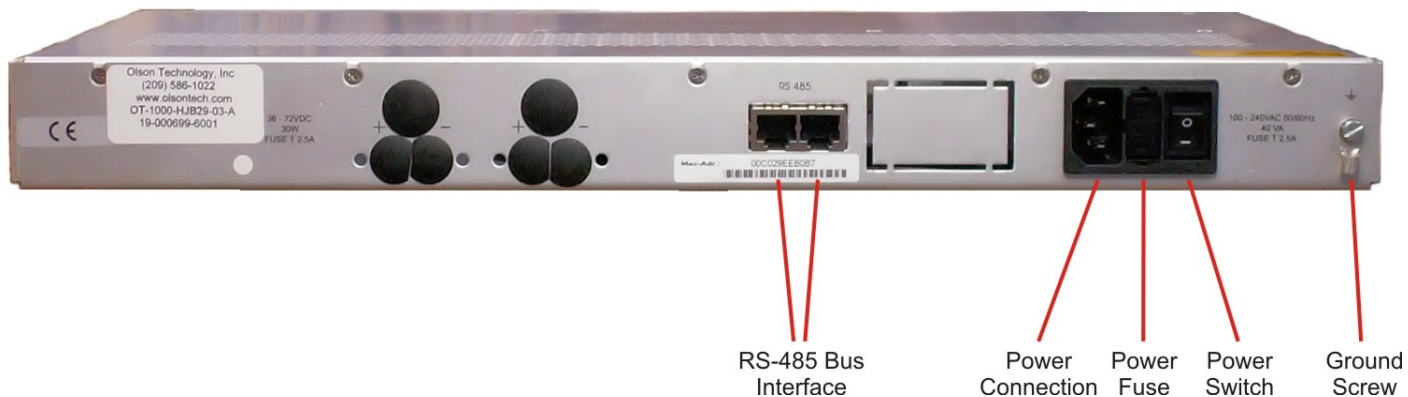

Figure 4 — Rear of OT-1000-HH

Power-Up Sequence

ATTENTION

- Be sure that the OT-1000-HH is put into operation under the recommended environmental conditions. Avoid temperature shocks after transportation of the OT-1000-HH and allow sufficient time to acclimate with the environmental conditions at the operating site.
- Mount the OT-1000-HH on an appropriate sub-rack or an outdoor housing and provide the required powering.
- After power on, the *STATUS* LED is Green.
- After this procedure, the LED's should indicate the status of the transmitter.

Setting Appropriate Operating Conditions

Optical Output Signal

A fiber optic cable with an appropriate, cleaned connector can be connected to the optical output, in order to feed a HFC network.



WARNING

Keep in mind that the OT-1000-HH is a laser class 1M product (according to IEC/EN 60825-1), which requires adequate safety precautions to avoid hazard to people working with it.

The transmitter's output power can be lowered from 0dB to -3dB. This feature is normally used for multi-channel DWDM applications where optical power balancing is required. It is recommended to keep the nominal optical output power (0dB) in all other cases.

RF Input Signal

For proper operation, an appropriate RF input signal within the specifications as given in this section should be applied at the input port.

The OT-1000-HH has a built-in RF power meter function, which monitors the total level at the input of the transmitter. This level depends on the number of carriers and their modulation scheme (AM-TV, FM-radio, 8VSB, and QAM). The input monitor controls the “RF” LED. As long as the input level is within the AGC range of the transmitter to obtain the specified total RMS modulation index (see below: AGC-On mode), the input LED is Green

- Typically, spectrum analyzers are used to measure the level of one carrier whereas the RF power meter function of the transmitter measures the total RMS (root mean square) power of all carriers together.

There are two principal modes (AGC-On/Off: automatic gain control on/off), which can be selected in order to operate the OT-1000-HH. Selection can be performed via an optional NEC (network element controller).

AGC-Off Mode for Narrowcast and Return Applications

In this mode, the user has the flexibility to change the gain of the internal RF amplifier according to special requirements to manually adjust the optical modulation index OMI. The total OMI_{totrms} is measured for the applied input signal at the selected RF gain, and can be monitored.

In the case of broadcast applications, this AGC-Off mode is for experienced users only. It should only be used with great care since the automatic protection against over modulation is lost! (See AGC-On mode below)

AGC-On Mode for Broadcast Application

In the AGC-On mode, the optical transmitter adjusts the optimum optical modulation index OMI by automatically adjusting the RF gain. The AGC-On mode is the recommended mode for standard broadcasting applications, where CATV signals (analog and digital video carriers, audio carriers) are transmitted.

Typically, about 5% is the optimum OMI for analog video carriers in broadcasting applications. In AGC-On mode, the transmitter will find the best modulation index by itself. The transmitter will also keep the best modulation index even if the RF input level varies. To do so, the transmitter makes use of its available RF gain range (RF Gain = -17 ... +7dB). If, for example 5% is indeed the optimum OMI – the RF input level of the analog video carrier can be in the broad level range of +13 to +37 dBmV. To have some operating safety margin, we recommend choosing an RF level in the range of 16 to 34 dBmV for 5%. Typical broadcasting applications will run with analog video carriers having input levels in this range.

Please note that the correct adjustment of RF input level is monitored by the transmitter!

NOTICE

When input power is lower or higher than required (out of required level range), the “RF” LED lights Red and an alarm is generated.

When input power is out of the recommended input level range (no safety margin any more) the “RF” LED turns Yellow and a warning is generated.

The AGC-On mode is also the recommended mode for test applications, where transmitter performance is measured. Most tests (CNR / CSO / CTB) are performed with un-modulated carriers using e.g. a Matrix generator or a CATV headend, where the video modulation is switched off. The OMI_{totrms} should be set to the factory setting (0dB). It is important to note that for AM-VSB TV channels the channel power level with modulation decreases by about 4dB (however, depending on the picture content). This decrease in input level has to be compensated by the AGC for optimum signal transmission (adjustment of optimum optical modulation index OMI).

The AGC-On mode function of the OT-1000-HH is factory adjusted to achieve a BER of 10^{-9} with most frequency plans. Experienced users are free to change the factory preadjustment by up to ± 3 dB and/or to use the OT-1000-HH in AGC-Off mode. This gives the flexibility to optimize the total system CNR or CSO/CTB performance, but it is recommended for very experienced users only.

ITU Frequency Adjustments for DWDM Applications (*)**

The OT-1000-HH offers the option to tune the optical frequency (wavelength) of the transmitter by ± 100 GHz in steps of 50 GHz. This option may be helpful in DWDM applications. For example, it can be used to reduce the number of spare transmitters by not keeping all used wavelengths in stock. The tuning can be performed via an OT-NEC-A (network element controller).

Return Application Adjustment (*)**

The OT-1000-HH transmitter can be used for return applications. Since AGC will not work for intermittent return path signal characteristics, the transmitter must be set in AGC-Off mode for return applications! Moreover, the alarms and warnings for OMI and RF Input Power should be masked! Due to the intermittent character of return path signals, the transmitter will generate OMI and/or RF Input Power alarms and warnings, but this condition is OK for return path application.

Redundancy Applications (Optical Power On /Off) (*)**

The transmitter can be configured as a back-up transmitter with optical output power off in redundancy applications (standby mode). The standby mode allows turning on the transmitter within less than 10 seconds. Therefore, situations where a fast switching to a redundant transmitter is requested can be implemented by using standby mode.

The optical power on/off switching can be performed via an OT-NEC-A (network element controller).

Software Setup (*)**

The detailed settings of the OT-1000-HH are performed using an OT-NEC-A network element controller.

LED Display and Alarms

The OT-1000-HH has three LED's displaying *Module*, *RF* and P_{OPT} status.

The table below shows an overview about what conditions trigger the LED's on the front panel. The STATUS LED summarizes the condition of the transmitter. The RF and P_{OPT} LED's give detailed information of the input and output status of the transmitter.

STATUS LED	Standard Operation	LED Green
	Non urgent alarm (warning)	LED Yellow
	Urgent alarm	LED Red

Input RF LED	Nominal RF input power	LED Green
	RF input power out of nominal operation	LED Yellow
	Loss of RF input power	LED Red

Output P_{OPT} LED	Nominal optical output power	LED Green
	Lack of optical output power	LED Yellow
	Loss of optical output power	LED Red
	Standby – operation	LED dark (switched off)

During a reset (after switching on) all LED's will be Yellow. After few seconds, all LED's will light green indicating normal operation.

In case of warnings (non-urgent alarms) and alarms (urgent alarms) the LED's indicate Yellow or Red. The warnings and alarms are described in the following.

STATUS LED States

Normal operation: STATUS LED Green

Non-urgent alarms: STATUS LED Yellow

- Laser aging: Laser bias current is >115% due to degradation (aging). Laser may need to be replaced.
- Laser temperature: Laser Peltier cooler current is >70 % of limit or laser temperature deviation more than 2°C. Improve ventilation in order to decrease the operating temperature.
- Module temperature: Module temperature is out of +5 to +70°C operating temperature range.
- SBS pilot level failure Internal network management failure

Urgent alarms: STATUS LED Red

- Laser aging: Laser bias current is >120% due to degradation (aging). Laser may need to be replaced.
- Laser temperature: Laser Peltier cooler current at limit or laser temperature deviation more than 3°C. Improve thermal heat flow in order to decrease the operating temperature.
- Module temperature: Module temperature is out of +5 to 70°C operating temperature range.
- SBS pilot failure
- Internal network management failure

In case of an urgent alarm, the transmitter should be switched off.

INPUT (RF) LED Status

Normal Operation: LED Green

Non-Urgent Alarm: LED Yellow

- RF input low or high
- In AGC-On mode: Input RF power is low or high and AGC gets out of range
- In AGC-Off mode: OMI_{totrms} is at the edge of its range

Urgent Alarm: LED Red

- RF-input is missing. RF input low or high
- In AGC-On mode: Input RF power is too low or too high and AGC is out of range
- In AGC-Off mode: OMI_{totrms} is out of range

OUTPUT (P_{OPT}) LED Status

Normal Operation: LED Green

Non-Urgent Alarm: LED Yellow

- The output power drops more than 0.5dB or increases more than 0.5dB (value can be adjusted by the user) relative to the nominal output power.
The transmitter is still working, but with reduced performance. It may need to be sent to Olson for maintenance. Call first to get an RMA.

Urgent Alarm: LED Red

- The output power drops more than 1.0dB or increases more than 1.0dB (value can be adjusted by the user) related to the nominal output power. The transmitter is not working properly. It may need to be sent to Olson for maintenance. Call first to get an RMA.