



OTMN-II
FOUR-OUTPUT, TWO-WAY
OPTICAL NODE
INSTRUCTION MANUAL

Phone: (209) 586-1022
(800) 545-1022
Fax: (209) 586-1026
E-Mail: salesupport@olsontech.com
www.olsontech.com

TABLE OF CONTENTS

INTRODUCTION	Page 3
GENERAL NOTES	Page 4
OPERATIONAL SETUP	
1. Select receiver operating wavelength	Page 5
2. Apply AC power	Page 5
3. Establish proper optical input level	Page 5
4. Set forward RF input level	Page 6
5. Set forward output level	Page 6
6. Set return band transmitter RF input level	Page 6
7. Verify return laser transmitter output power	Page 6
8. Redundant receiver and transmitter option	Page 7
FIGURE 1: Block Diagram	Page 8
FIGURE 2: Wavelength Jumper - “A” Receiver	Page 9
FIGURE 3: Wavelength Jumper - “B” Receiver	Page 10
SPECIFICATIONS	Page 11
OTMN-2-414-AC - Manual Addendum	Page 12

INTRODUCTION

The OLSON TECHNOLOGY OTMN-II is a high performance, four-output, two-way optical node capable of greater than +50dBmV output levels and performance to 870MHz or optional 1GHz.

The OTMN II is configured in a finned weatherproof aluminum housing suitable for outdoor strand or pedestal installation. It is specifically designed to operate over wide temperature ranges, and operates from standard CATV 60 V_{AC} power. The optical receiver and return laser transmitter have SC-APC optical connectors. Internal RF connections are made with 75Ω mini-SMB connectors. RF test points are male Type “G” connectors and mate with standard adapters.

Cable and fiber entry and exit ports accept standard 5/8-24 threaded CATV connectors. RF and power connections should be made with standard KS-Type pin-style connectors with a 0.067 inch center conductor should be used only. The length of the center conductor pin must be between 1.4 and 1.55 inches when measured from the seating area of the connector to the tip of the center conductor.

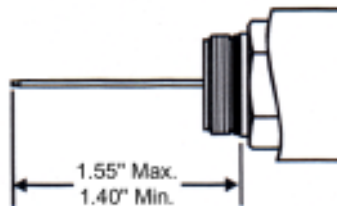

The OTMN-II has four identical bi-directional coaxial ports. Each port has a forward (downstream) passband of 54-870MHz (or optional 1GHz) and a reverse (upstream) passband of 5-42MHz. Optional passband frequencies of 85-870MHz (or optional 1GHz) and 5-65MHz are available.

All four bi-directional ports are capable of passing power into or out of the OTMN-II. A fifth port designated as a power port can be optionally configured to also serve as an RF port for return-band signals into or out of the housing. Jumper plugs controlling the power configuration for each of the ports can be replaced with automotive-type ATC fuses.

A fiber-organizing tray is included for management of input and output fibers.

Internal construction is modular and all modules are field replaceable.

The OTMN II has provisions for an optional or user-supplied status transponder and can be configured with an optional redundant optical receiver and/or 2nd optical transmitter.

Module features allow setup of forward and reverse path gains and levels by means of plug-in attenuators. A plug-in equalizer controls forward frequency response of the OTMN-II. Forward and reverse -20dB test points are provided and DC test points are provided for received optical power level and return laser transmitter output power.

GENERAL NOTES

- ❑ Figure one is a simplified block diagram of the OTMN-II.
- ❑ Before operating or closing the OTMN-II, check that the six(6) main chassis mounting screws, the return laser transmitter mounting screws, the two optical receiver mounting screws, and the two power supply mounting screws are firmly and evenly tightened. Also, check the mounting screws of any optional modules. The mounting screws are retained by O-rings or C-clips and they should be checked to ensure that they are present and are pressed all the way towards the module.

When installing a module, tighten its mounting screws in steps, alternating from screw-to-screw until all are seated. After this, tighten them firmly.

Inspect all modules for any visible indication that they may not be fully seated to the mounting surface. See the thermal conductive material note, next.

- ❑ All modules have a thermally conductive material applied to their mounting surface. This material is an important part of the OTMN II thermal management design. It must be present as originally installed. This material is somewhat soft and can be damaged by abuse or mishandling. If a module is removed for any reason, care should be taken to prevent damage to this material. Be sure that no debris gets between the thermally conductive material and the surface it mounts-to. This material will raise its module off the mounting surface somewhat and this should not be confused with a module that is not fully seated.
- ❑ Internal RF jumpers are terminated with 75Ω mini-SMB connectors. These connectors must be handled carefully and can be damaged if they are inadvertently abused. The mating connectors in modules can also be damaged by inadvertent abuse of the RF jumper cables.

When moving (unplugging) a connector from a module, **BE SURE TO PULL IT STRAIGHT UP AWAY FROM THE MODULE**. A tool such as a pair of pliers or a large pair of needle-nose pliers used carefully will aid in unplugging the connectors without damage.

When plugging a connector onto a module connector, **BE SURE TO PRESS IT STRAIGHT DOWN ONTO THE MODULE CONNECTOR**. Press it down until the first “click” is felt or heard.

- ❑ When closing a housing after installing or otherwise working with the OTMN-II, be sure to tighten all six of the housing closure screws firmly and evenly. Use a cross-pattern (do not tighten adjacent screws). After all are tight, double-check all six.
- ❑ Recommended fastener torque.
 - A. Optical receiver, laser transmitter, and block converter mounting screws : 10in/lbs
 - B. Power supply mounting screws : 20in/lbs
 - C. Main chassis center mounting screws (2) : 30in/lbs
 - D. Main chassis outer mounting screws (4) : 8in/lbs
 - E. External housing closure bolts : 40in/lbs

OPERATIONAL SETUP

DANGER-LASER CAUTION-DANGER

THIS UNIT CAN EMIT INVISIBLE LASER RADIATION FROM THE LASER TRANSMITTER
AVOID DIRECT EXPOSURE TO BEAM

OPERATE ONLY WITH PROPER OPTICAL FIBER INSTALLED IN TRANSMITTER CONNECTOR

1. Select receiver operating wavelength:
 - ❑ The OTMN-II optical receiver will function properly in 1310nm and 1550nm systems. The receiver has a 2-pin jumper that must be in the proper position based on the optical input wavelength.
 - ❑ Refer to figures two and three in this manual for information on proper positioning of this jumper.
2. Apply AC Power:
 - ❑ The OTMN II may be powered from any port (1 through 5) and can provide outgoing power to any of the remaining ports.
 - ❑ Determine how the OTMN-II is to be powered (through which port).
 - ❑ Plug the provided jumpers (or user-supplied fuses) into locations F1 through F5 as required to power the unit and or to provide outgoing power to ports 1 through 5.
 - ❑ Apply 60V_{AC} (Nominal) power to the selected power input port.
 - ❑ Verify that the receiver “status” LED is on (may be red or green).
 - ❑ If the unit is equipped with a return laser transmitter, its “status” LED should be on and green. If it is on and red, there is a transmitter fault.
 - ❑ If it is desired to measure the actual DC voltages, the rear (wire entry side) of the “DC Input” cable connector can be probed. The yellow wire pin should have 5.2V_{DC} present and the red wire pin should have 13.5V_{DC} present. Both measurements are referenced to chassis ground.
3. Establish proper optical input level:
 - ❑ The optical input level should be between -4dBm and +2dBm (0.4mW to 1.58mW) for proper operation.
 - ❑ Connect the optical signal to the receiver input and measure the DC level at the receive power test point. This test point is scaled at approximately +1 V_{DC}/mW. 1.5V_{DC} for example, would indicate 1.5mW and 0.5V_{DC} would indicate 0.5mW. Table 1 shows the relationship between the TP voltage and optical power.

Table 1

Optical Input (dBm)	Test Point (Volts)
-4	0.40
-3	0.50
-2	0.63
-1	0.80
0	1.00
+1	1.25
+2	1.58
+3	2.00 (Over recommended maximum)

NOTES:

- A. The receiver “status” LED will be green for input levels between approximately 0.25mW and 2.50mW. This LED will be red for optical levels below or above this range. This can serve to quickly indicate if the input level is out of range.
- B. If the optical input is measured with an optical power meter before the fiber is connected to the receiver, the receive power test point can be metered to verify a good optical connection to the receiver input.

4. Set forward RF input level:

- ❑ The OTMN-II is set at the factory for a -1dBm optical input and a +50dBmV output at all four ports with a 10dB slope for 870MHz units. 1GHz units have 12dB slope and +48dBmV.
- ❑ The source optical transmitter should have as an input, a 550MHz carrier (547.250MHz) at the planned operational level. This carrier will be used to establish the OTMN-II output level.
- ❑ Install 0dB attenuators at the receiver pad and forward input pad locations.
- ❑ Select and install an equalizer at the forward input equalizer location in the main chassis (or verify that an equalizer is installed).
- ❑ Measure the level of the 550MHz carrier at the forward input -20dB test point. For proper operation, this carrier should be at approximately +14dBmV actual (-6dBmV at the test point).

If the 550MHz carrier level is below +14dBmV (-6dBmV at test point) the system may not perform to specifications.

If the 550MHz carrier is at +14dBmV, (-6dBmV at test point) proceed to the next section (set forward output level).

If the 550MHz carrier is greater than +14dBmV, (-6dBmV at test point) attenuation will have to be added to reduce it to the proper level.

- ❑ The receiver pad location or the forward input pad location (or both) can be used to attenuate the forward RF input level to +14dBmV actual (-6dBmV at test point). Select an attenuator or combination of attenuators that will result in the correct level. If one attenuator is used, the other position must be a "0"dB pad. Verify that the level is at +14dBmV actual (-6dBmV at test point) after the attenuators are installed.

5. Set forward output level:

- ❑ Terminate ports 1 through 4 with 75Ω. This may be done with terminators or intended feeder cables but the outputs must be properly terminated.
- ❑ Install an attenuator at the forward pad location for each of the four ports. This may be any convenient value.
- ❑ Measure the forward output level of the 550MHz carrier for port 1 at the forward port 1 -20dB test point.
- ❑ Select an attenuator value that will set the level of the 550MHz carrier to the desired value - typically ≤ +50dBmV actual (+30dBmV at the test point). (**Note: 1GHz levels will be 2dB lower.**) Place this attenuator at the forward pad location and verify that the 550MHz carrier level is as required.
- ❑ In the same fashion, set the forward output level of ports 2, 3, and 4.

6. Set return band transmitter RF input level:

- ❑ The specification for the return band transmitter RF input level is -57dBmV/Hz (measured at the OTMN II external ports). This value operates the system at the NPR threshold.
- ❑ The OTMN II has a plug-in attenuator in the reverse path from each port. Also included are -20dB test points in the return path from each port. Note that the -20dB test points are before the plug-in attenuators.
- ❑ The single carrier equivalent of -57dBmV/Hz is +9dBmV. Pads must be selected to set the return carrier levels to +9dBmV actual, after the attenuator.
- ❑ With a test carrier present at a given port, measure its level at the reverse -20dB test point for that port. Use the actual level (test point +20dB) measured, to determine what value of attenuator must be used to provide +9dBmV after the attenuator.

7. Verify return laser transmitter output power:
 - The return laser transmitter has a DC test point for optical power. This test point is scaled at approximately $1V_{DC}/mW$.
 - Measure the DC test point and verify that the reading is equivalent to the specified output power of the installed transmitter. For example, a 3mW DFB laser transmitter should have $3V_{DC}$ at its test point.

8. Redundant receiver and transmitter option:
 - If the OTMN-II is equipped with a redundant receiver and transmitter, the previous steps must be applied to them also
 - On the receiver front panel, use the toggle switch to select receiver “A” or “B” for set-up. Return to the auto position for redundant operation.

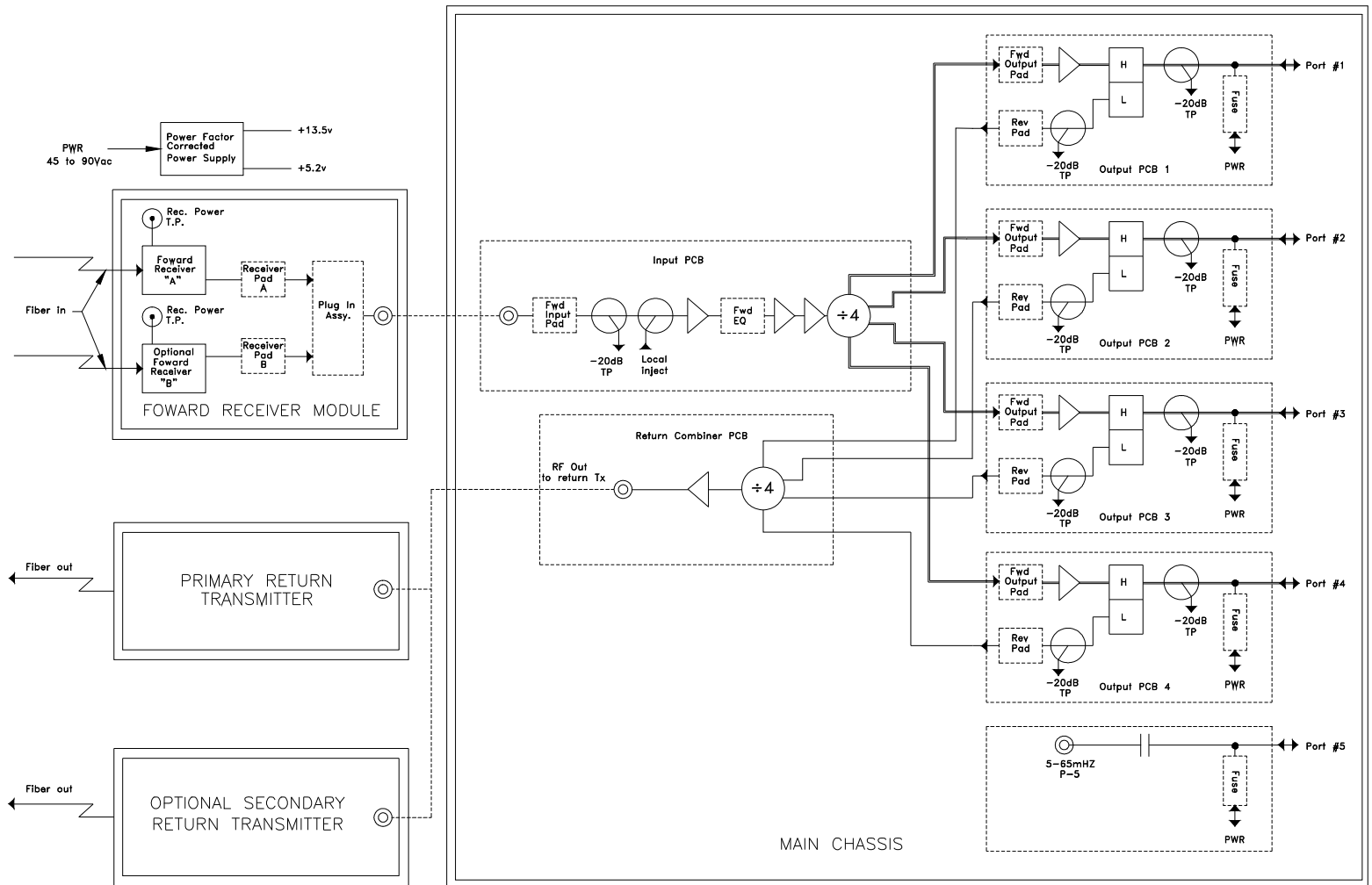

FIGURE 1

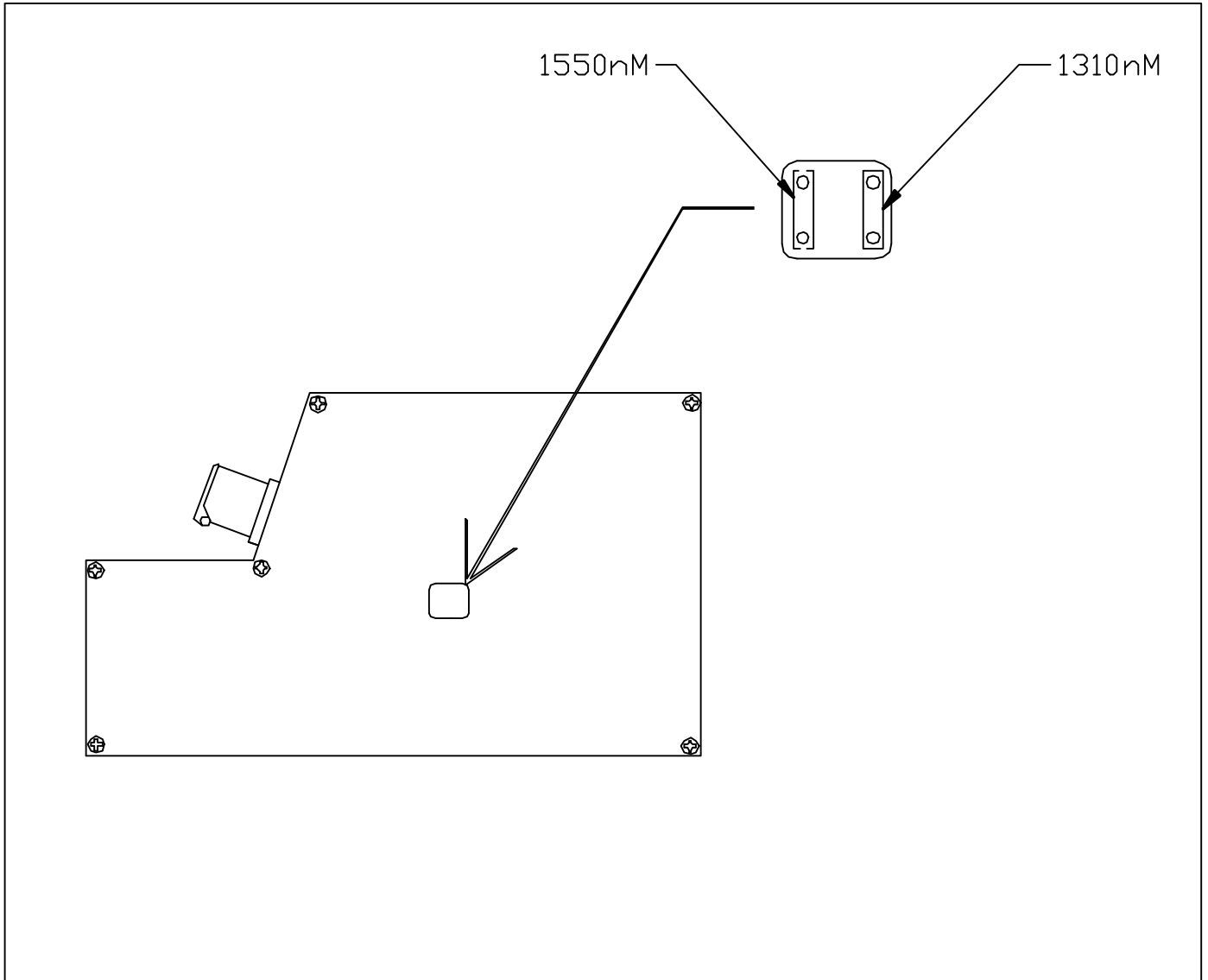

FIGURE 2
"A" Receiver

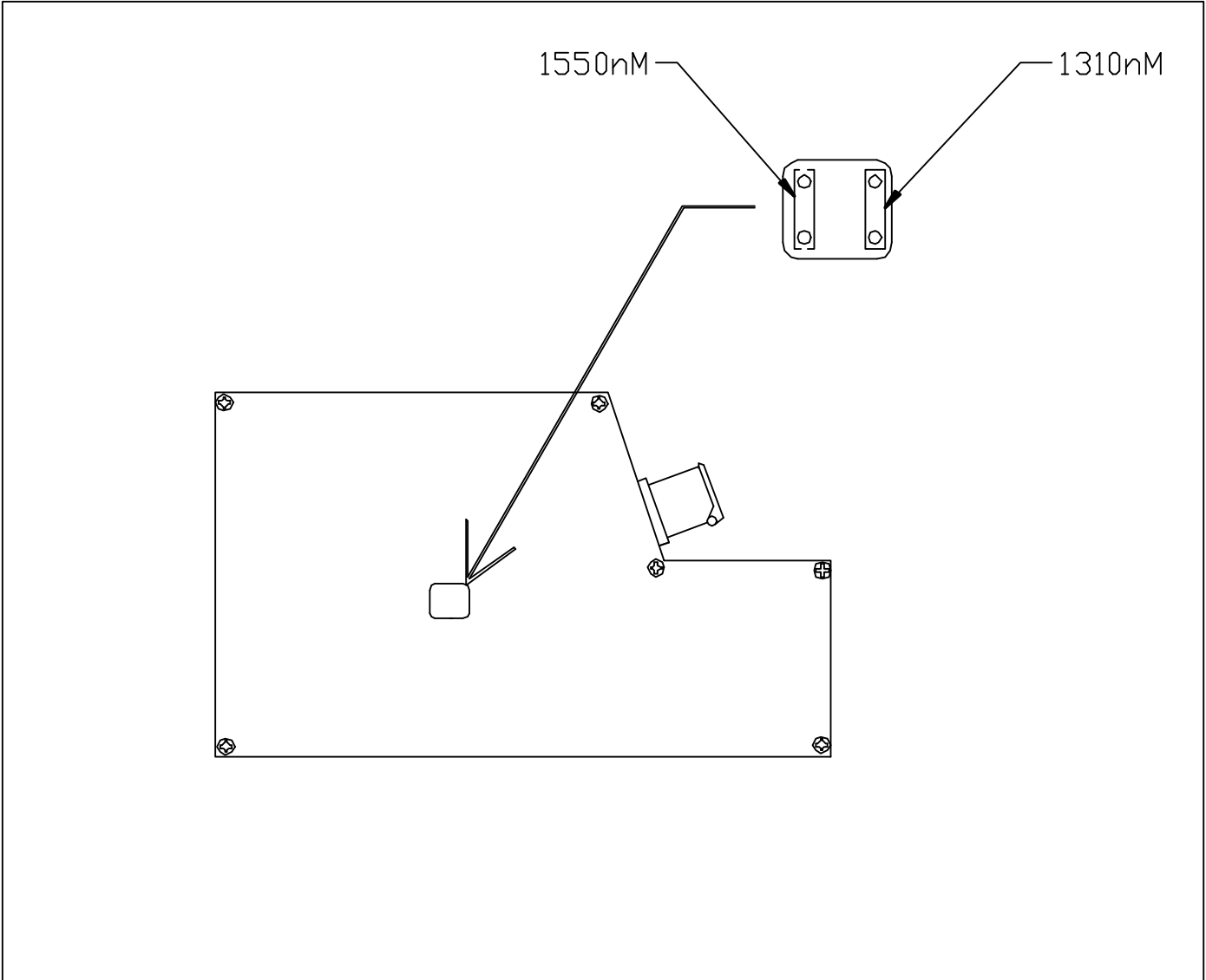

FIGURE 3
"B" Receiver

SPECIFICATIONS

Optical Input Range.....	-4dBm to +2dBm	
Forward Frequency Range.....	54MHz to 870MHz (Optional to 1GHz)or 85MHz to 870MHz (Optional to 1GHz) - <u>Option1</u>	
Reverse Frequency Range.....	5MHz to 42MHz or 5MHz to 65MHz - <u>Option 1</u>	
Forward Frequency Response.....	<±0.75dB to 870MHz <±1.0dB to 1GHz	
Reverse Frequency Response.....	<±0.75dB 5MHz to 42MHz or 5MHz to 65MHz	
Output Level (Forward).....	+50dBmV @ 550MHz (+48dBmV for 1GHz model.) Each of four outputs	With -4dBm optical input, 16dB slope to 870MHz, and Transmitter OMI @ 3.2%.
Distortion.....	>62dB CSO/CTB @ above output and +2dBm optical input. Carrier loading (77 channels) to 550MHz. Simulated data loading @ -6dB from 550MHz to 870MHz.	
Carrier to Noise.....	>53dB @ -1dBm optical or greater. Carrier loading (77 channels) to 550MHz.	
In/Out Return Loss.....	>16dB - All ports 1 through 4 (14dB to 1GHz) Port 5 (power port) - >15dB to 65MHz with optional return port configuration.	
Return Laser Output Power.....	3.0mW ± 0.5mW	
With DFB Return Laser		
Return Path NPR.....	Range over 41dB NPR is >15dB measured with 10dB of fiber and with OLSON TECHNOLOGY return band receiver.	
With DFB Return Laser		
Return Path NPR.....	Range over 41dB NPR is as follows:	
With Block Converter Option	1) >15dB measured with 10dB of fiber as above but with one band variable and the second band at the NPR threshold.	
With DFB Return Laser	2) >13dB measured with 10dB of fiber as above and both bands moving together.	
Return Path NPR Threshold.....	< -57dBmV / Hz	
Operating Temperature Range.....	-40°C to +65°C	} FORWARD REVERSE
Gain Variation vs. Temperature.....	<±1dB typical <±1.5dB Max <±1.8dB	
AC Power Requirements.....	60 V _{AC} @ 50-60Hz; (45V _{AC} to 90V _{AC}) Will withstand over-voltage to 140V _{AC} .	
Internal Test Points.....	See unit diagram for functional description and location.	
Hum Modulation.....	>60dB @ 15 Amps AC current from any one port 7MHz to 25MHz. >65dB @ 15 Amps AC current from any one port 25MHz to 870MHz.	

OTMN-2-414-AC

Manual Addendum

DESCRIPTION

The OTMN-2-414-AC is a specially equipped OTMN-II node with a dual optical input, RF band-split receiver. Receiver A receives ITU channel 38 from the optical splitter (if equipped) and receiver B is for ITU channel 34. The RF from each receiver is combined in a diplex filter. Receiver A passes 444-870MHz while receiver B passes 54-444MHz. The output of each receiver is combined and inserted into the OTMN-II main RF assembly. The output level from each of the OTMN-II's four output ports is +45dBmV per channel at 547.25MHz.

ALIGNMENT

When setting up the node, in most cases receiver A and B should have similar optical test point voltages. These voltages will generally be between $0.6V_{DC}$ to $1.2V_{DC}$ when installed into the system. Because the optical input level will vary from node to node, it may be necessary to adjust the RF output level for each node. There are several locations where this level can be changed. Each receiver has its own respective plug-in PAD. This PAD only effects the output level of the receiver that it is plugged into. These PADs are used if one receiver has a higher output level than the other. The third place to adjust the RF output effects the total combined output level. This PAD is located in the main RF assembly and is labeled as the FWD INPUT PAD. This PAD is used to adjust the total output power of the whole node. If required, each port can have its output level changed individually via the PAD locations at FWD1, FWD2, FWD3, and FWD4.

When adjusting output levels, the first step is to verify that the output level of each receiver is the same. To do this, measure the levels at 223.25MHz and 547.25MHz via the FWD INPUT -20dB test point on the main RF assembly. These two levels should be as close to equal as possible. If one level is higher than the other, then change the PAD in the receivers until they are close to equal. Once these levels are the same, the main output ports can be adjusted with the FWD Input PAD for output level at all four ports. These should be set to +45dBmV per channel at 547.25MHz, and can be set via the FWD1, FWD2, FWD3, and FWD4 -20dB test points.