



OPTICAL HEADEND PLATFORM

OTOHP-FTX FORWARD PATH 1310nm TRANSMITTER

INSTRUCTION MANUAL



Phone: (209) 586-1022

(800) 545-1022

Fax: (209) 586-1026

E-Mail: salesupport@olsontech.com

www.olsontech.com



SAFETY WARNINGS

LASER RADIATION



The OTOHP-FTX laser transmitter emits invisible radiation that can cause permanent eye damage. ***AVOID DIRECT EXPOSURE TO BEAM.*** Operate the transmitter only with the proper optical fiber installed in the transmitter optical connector. Power to the transmitter should be turned-off or preferably, disconnected whenever the optical connector cover is opened and there is no installed fiber (as when the fiber connector is being installed or removed from the transmitter connector).

NEVER USE ANY OPTICAL INSTRUMENT TO VIEW THE OUTPUT OF THE LASER TRANSMITTER. "OPTICAL INSTRUMENT" INCLUDES MAGNIFYING GLASSES, ETC.

NEVER LOOK INTO THE OUTPUT OF THE LASER TRANSMITTER

NEVER LOOK INTO THE OUTPUT OF A FIBER CONNECTED TO A LASER TRANSMITTER.

NEVER LOOK INTO OR USE ANY OPTICAL INSTRUMENT TO VIEW THE DISTANT END OF A FIBER THAT MAY BE CONNECTED DIRECTLY OR VIA AN OPTICAL SPLIT, TO A TRANSMITTER THAT MAY BE OPERATING. THIS SPECIFICALLY APPLIES TO FIBERS THAT ARE TO BE CONNECTED TO RECEIVERS OR OTHER DEVICES AT ANY DISTANCE FROM THE LASER TRANSMITTER.

PRECAUTIONS

Failure to comply with these general safety precautions and with the specific precautions described elsewhere in this manual violates the safety standards of the design, manufacture, and intended use of the device. Olson Technology Inc. assumes no liability for the customer's failure to comply with these precautions.

Do not operate the transmitter outside of its ratings. Doing so may result in unsatisfactory performance, receiver failure, shortened receiver life span, or a safety hazard.

Do not attempt to modify or service any part of a transmitter module. Doing so voids the warranty. Contact Olson and request an RMA number and return the unit to Olson Technology Inc. for service and repair.

Do not restrict airflow in front of or behind the chassis. The transmitter should be operated in an ambient environment between 0 and 50°C (32 and 122°F).

Store the module away from corrosive materials, at a temperature between -40 and +70°C (-40 and +158°F), and with no more than 85% humidity, non-condensing.

INTRODUCTION

The OTOHP-FTX series is a high performance 1310nm DFB laser transmitter module that is ideal for broadcast and narrowcast applications in optical transportation. The modules are available over wide range of optical output power to deliver both analog and (QAM) CATV digital signals. High performance, advanced pre-distortion circuitry achieves superior CSO and CTB. All configuration parameters of modules can be monitored by LED screens on the front panel of the module, or by the OTOHP-NMS equipment management module. The OTOHP-FTX module can be operated also by Automatic Gain Control (AGC) or Manual Gain Control (MGC) modes. These modes can be set up on the front panel.

OPERATION PANEL DESCRIPTION

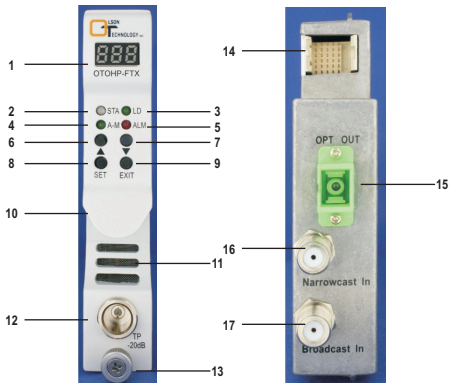

1. Display LED: Display the status, AGC & MGC value and alarm code of the transmitter.
2. STA LED: Green indicates the module is operating properly. Red indicates the module has alarms.
3. LD LED: When green, the OTOHP-FTX module is working under “LD” operation interface.
4. A-M LED: When green, the OTOHP-FTX module is working under “AGC & MGC” operation interface.
5. ALM LED: When green, the OTOHP-RRX module is working under “ALM” operation interface.

OPERATION PANEL DESCRIPTION (CONT.)

7. Down: Push button, selects function or parameter setting.
8. Set: Push button, confirm function or parameter setting selection.
9. Exit: Push button, exit certain operation mode.
10. Handle: Used to handle the module when being installed or uninstalled.
11. Heat dissipation hole: Air flow out of this hole dissipates the heat.
12. TP: Test point for RF output, F type male connector.
13. Thumbscrew: Fixes the module to the chassis.
14. 30-pin Connector: Provides power and signals to the chassis backplane, connector type is male.
15. Optical Output Port: Port for optical output, connector type is SC/APC.
16. Narrowband In RF Port: Narrowband RF input, connector type is F-female.
17. Broadcast In RF Port: Broadband RF input, connector type is F-female.

INSTALLATION

1. Inspect for bent pins on the backplane connector at the rear of the module. Straighten any bent pins before installing the module.
2. Gently insert each module into a slot in the front of the chassis. Be careful to align the metal guide rails on the top and bottom of the module with the nylon guides in the interior of the chassis housing.
3. Tighten the captive thumbscrew on the front of the module.

Note: If the power supply turns on after the OTOHP-FTX 1310nm optical transmitter is inserted, the Display LED will flash for 5 seconds, indication the transmitter is self-checking.

4. Repeat Steps 1 through 3 to install the remaining modules in the chassis.
5. Ensure that the correct RF level is being applied at the associated forward path transmitter. CAUTION: Input RF power levels lower than +11dBmV/per channel can reduce the RF performance of the transmitter module.
6. Connect the RF cabling to the appropriate RF IN connector on the rear panel. Note: The narrowband input level should be 12dB higher than the input level of broadband. Ensure the frequencies are not the same when both narrowband and broadband inputs are being used.

INSTALLATION (CONT.)

- Using a signal level meter, measure the RF input at the RF TP test-point (20dB below actual level) on the front panel and verify that it is set at the specified value for that channel. Further adjust the RF input level if required.
- Verify that the correct optical connector will be attached to the optical connector on the module. Clean both the bulkhead and fiber connectors. CAUTION: Using mismatched optical connectors will damage the connectors and degrade system performance. Ensure that each fiber has a matching connector.
- Connect the optical fibers to the appropriate OPT OUT connection on the rear panel. Then turn on the laser from the front panel (instructions are below).
- Use an optical power meter to verify that the optical output level meets specifications.

FRONT PANEL NUMERIC DISPLAY OPERATION DESCRIPTION

First push SET on the LED display and set function.

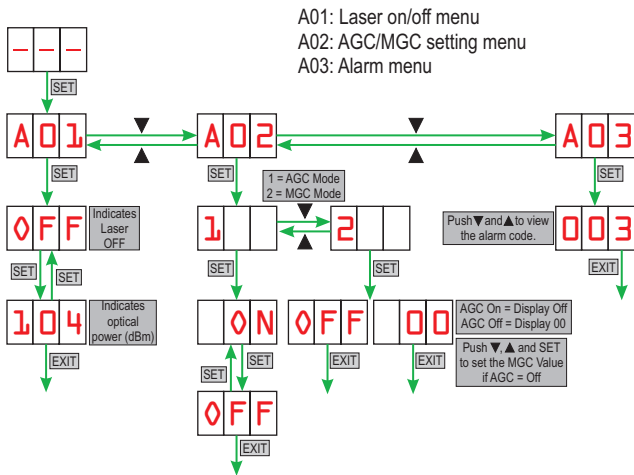

UNINSTALL THE TRANSMITTER MODULES

DANGER: Laser Radiation—Avoid direct exposure to beam. Inbound laser radiation associated with this optical output jumper is generated by a Class IIIb laser product. Disconnected optical connectors might emit invisible optical radiation. Laser light, visible or invisible, can seriously injure eyes and even cause blindness.

1. Disconnect the optical fiber(s) from the rear panel of the transmitter. Immediately place protective caps over the bulkhead and fiber connector.
2. Disconnect the RF cables from the F-connectors.
3. Loosen the thumbscrew on the front panel of the module. CAUTION: Do not pull on the thumbscrew to remove the module. Pull on the handle that the thumbscrew goes through to remove the module.
4. Gently pull the module from the chassis using the handle that the thumbscrew goes through.

ALARM DEFINITIONS

First push SET on the LED display and set function.

Displayed Message	Alarm Status	System Response
000	No alarm	STA LED is green
001	Optical output low	STA LED turns to red
002	Optical output high	STA LED turns to red
003	Laser bias high	STA LED turns to red
004	Laser temperature high	STA LED turns to red
005	RF input low	STA LED turns to red
006	Module temperature high	STA LED turns to red
007	TEC current high	STA LED turns to red
008	RF input high	STA LED turns to red

TROUBLESHOOTING

When the Status light is red, the operator can use “▲”, “▼” and “SET” push button switch to check the alarms. DANGER/CAUTION: Do not remove the cover of the transmitter or attempt to modify any part of it under any circumstances. Removing the cover could cause irreparable damage to the unit, and will void your warranty.

TROUBLESHOOTING (CONT.)

Problem	Steps to Take
RF input low.	<ol style="list-style-type: none"> 1. Verify RF input power is correct. 2. If all is normal, contact Olson Technology Inc. for further troubleshooting.
No optical power at the optical output port.	<ol style="list-style-type: none"> 1. Clean the connector. 2. Verify laser function is set on. 3. Measure the optical power at the output port using an optical power meter. 4. If there is no optical power at the output port, the unit must be returned to the factory for service. Contact Olson Technology Inc. for more information.
Optical power is lower than the required amount.	<ol style="list-style-type: none"> 1. Ensure all connectors are clean. 2. Verify the cable is terminated with the correct connector type. 3. Measure the optical power at the output port using an optical power meter. 4. If the optical power is still low, the unit must be returned to the factory for service. Contact Olson Technology Inc. for more information.

Typical CNR Performance

Loss Power	0dB	1dB	2dB	3dB	4dB	5dB	6dB	7dB	8dB
+3dBm			53	52	51	50			
+6dBm						53	52	51	50
Loss Power	7dB	8dB	9dB	10dB	11dB	12dB	13dB	14dB	15dB
+8dBm	53	52	51	50					
+10dBm			53	52	51	50			
+12dBm					53	52	51	50	
+13dBm						53	52	51	50

SPECIFICATIONS

Optical Characteristics (with SM 9/125 μ m Fiber)

	Min	Typ	Max	Units
Operating Wavelength	1290		1330	nm
Optical Output Power	+3		+13	dBm
Optical Return Loss		-55		dB
Optical Output Ports		1		
Optical Connector	SC/APC			

RF Output & Performance Characteristics

	Min	Typ	Max	Units
Frequency Range	54		1,000	MHz
Band Flatness ₁	-0.75		+0.75	dB
RF Input Return Loss		16		dB
RF Input - Broadband	+11		+19	dBmV
RF Input - Narrowband	+23		+31	dBmV
RF TP - Broadband	-21	-20	-19	dB
RF TP - Narrowband	-33	-32	-31	dB
Impedance		75		Ohms
CSO ₂			-63	dB
CTB ₂			-67	dB
XMOD ₂			-65	dB
RF Connectors	F-female			

NOTES:

- 1) Band flatness is over a 54-1,000MHz range.
- 2) 15km fiber + attenuator, receive power -1dBm, NTSC 77.
- 3) Non condensing.

Electrical & Environmental Characteristics

	Min	Typ	Max	Units
Operating Temp. Range	0		+50	°C
Storage Temp. Range	-40		+65	°C
Relative Humidity ₃	10		85	%
P. S. Voltage	+24			V _{DC}
Power Consumption			12.5	W