



## OPTICAL HEADEND PLATFORM

### OTOHP-RRX QUAD REVERSE RETURN PATH RECEIVER

### INSTRUCTION MANUAL



Phone: (209) 586-1022

(800) 545-1022

Fax: (209) 586-1026

E-Mail: [salesupport@olsontech.com](mailto:salesupport@olsontech.com)

[www.olsontech.com](http://www.olsontech.com)



## **SAFETY WARNINGS**

### **LASER RADIATION**



The optical fiber connector attached to the OTOHP-RRX receiver emits invisible radiation that can cause permanent eye damage. ***AVOID DIRECT EXPOSURE TO BEAM.*** Operate the receiver only with the proper optical fiber installed in the receiver optical connector. Power to the receiver should be turned-off or preferably, disconnected whenever the optical connector cover is opened and there is no installed fiber (as when the fiber connector is being installed or removed from the transmitter connector).

**NEVER** USE ANY OPTICAL INSTRUMENT TO VIEW THE OUTPUT OF THE OPTICAL FIBER OR CONNECTOR “OPTICAL INSTRUMENT” INCLUDES MAGNIFYING GLASSES, ETC.

**NEVER** LOOK INTO THE OUTPUT OF THE CONNECTOR TO BE ATTACHED TO THE RECEIVER

**NEVER** LOOK INTO THE OUTPUT OF A FIBER CONNECTED TO A LASER TRANSMITTER.

**NEVER** LOOK INTO OR USE ANY OPTICAL INSTRUMENT TO VIEW THE DISTANT END OF A FIBER THAT MAY BE CONNECTED DIRECTLY OR VIA AN OPTICAL SPLIT, TO A TRANSMITTER THAT MAY BE OPERATING. THIS SPECIFICALLY APPLIES TO FIBERS THAT ARE TO BE CONNECTED TO RECEIVERS OR OTHER DEVICES AT ANY DISTANCE FROM THE LASER TRANSMITTER.

## **PRECAUTIONS**

Failure to comply with these general safety precautions and with the specific precautions described elsewhere in this manual violates the safety standards of the design, manufacture, and intended use of the device. Olson Technology Inc. assumes no liability for the customer's failure to comply with these precautions.

Do not operate the receiver outside of its ratings. Doing so may result in unsatisfactory performance, receiver failure, shortened receiver life span, or a safety hazard.

Do not attempt to modify or service any part of a receiver module. Doing so voids the warranty. Return the unit to Olson Technology Inc. for service and repair.

Do not restrict airflow in front of or behind the chassis. The receiver should be operated in an ambient environment between 0 and 50°C (32 and 122°F).

Store the module away from corrosive materials, at a temperature between -40 and +70°C (-40 and +158°F), and with no more than 85% humidity, non-condensing.

## INTRODUCTION

The Olson Technology, Inc. Model OTOHP-RRX is a quad return path receiver module optimized for good performance over a wide range of optical levels. This low-noise receiver converts upstream optical signals into RF signals at the headend or remote hubs. Internal selectable RF attenuators can be switched in or out to enable each receiver to handle a very wide range of optical input signals. The module features four completely independent receivers with four RF output ports, which are located on the rear panel. The OTOHP-RRX provides +45dBmV output level. The front panel controls allow local management and monitoring of the module while the RS-485 interface and the OTOHP-NMS network management module allow remote management and monitoring of the module.

### OPERATION PANEL DESCRIPTION

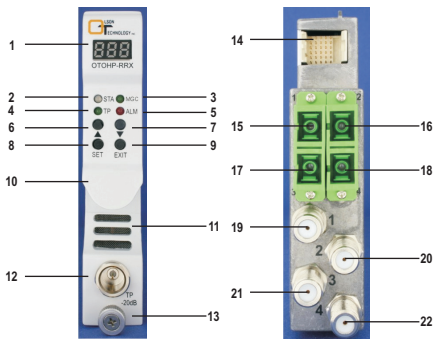

1. Display LED: Display the status, MGC value and alarm code of the receiver.
2. STA LED: Green indicates the module is operating properly. Red indicates the module has alarms.
3. MGC LED: Green indicates the module is operating under MGC operation interface.
4. TP LED: Green indicates the module is working under "TP" operation interface
5. ALM LED: When green, the OTOHP-RRX module is working under "ALM" operation interface.
6. Up: Push button, selects function or parameter setting.

## OPERATION PANEL DESCRIPTION (CONT.)

7. Down: Push button, select function or parameter setting.
8. Set: Push button, confirm function or parameter setting selection.
9. Exit: Push button, exit certain operation mode.
10. Handle: Used to handle the module when being installed or uninstalled.
11. Heat dissipation hole: Air flow out of these holes dissipates the heat.
12. TP: Test point for RF output, -20dB, F type male connector.
13. Thumbscrew: Fixes the module to the chassis.
14. 30-pin Connector: Provides power and signals to the chassis backplane. connector type is male.
15. Optical Input Port: Port for optical input, connector type is SC/APC.
16. Optical Input Port: Port for optical input, connector type is SC/APC.
17. Optical Input Port: Port for optical input, connector type is SC/APC.
18. Optical Input Port: Port for optical input, connector type is SC/APC.
19. RF Input Port: Port for RF input, connector type is F-female.
20. RF Input Port: Port for RF input, connector type is F-female.
21. RF Input Port: Port for RF input, connector type is F-female.
22. RF Input Port: Port for RF input, connector type is F-female.

## INSTALLATION

1. Inspect for bent pins on the backplane connector at the rear of the module. Straighten any bent pins before installing the module.
2. Gently insert each module into a slot in the front of the chassis. Be careful to align the metal guide rails on the top and bottom of the module with the nylon guides in the interior of the chassis housing.
3. Tighten the captive thumbscrew on the front of the module.

*CAUTION: Using mismatched optical connectors will damage the connectors and degrade system performance. Ensure that each fiber has a matching connector.*

4. Repeat Steps 1 through 3 to install the remaining modules in the chassis.
5. Use an optical power meter to verify that the optical input level on specification value.

## INSTALLATION (CONT.)

*Note: If the power supply turns on after the OTOHP-RRX reverse return path receiver is inserted, the Display LED will flash for 5 seconds, and indication the receiver is self-checking.*

- Verify that the correct optical connector will be attached to the optical connector on the module. Clean both the bulkhead and fiber connectors.
- Connect the optical fibers to the appropriate OPT IN adapter on the rear panel.
- Connect the RF cord to the appropriate RF OUT connector on the rear panel.
- Push the SET button and set the RF TP channels. Using a signal level meter, measure the RF output at the RF TP test point (20dB below actual level) on the front panel and verify that it is set at the specified value for that channel. Further adjust the RF output level if required using MGC function.

### FRONT PANEL NUMERIC DISPLAY OPERATION DESCRIPTION

First push SET on the LED display and set function.

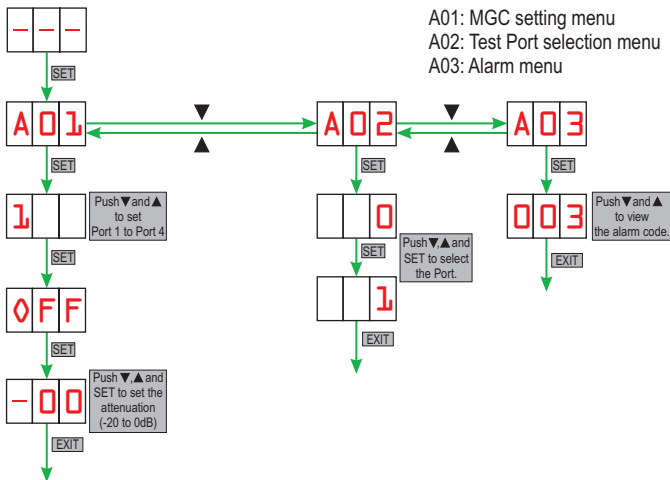

## UNINSTALL THE RECEIVER MODULES

**DANGER: Laser Radiation—Avoid direct exposure to beam. Inbound laser radiation associated with this optical input jumper may be generated by a Class IIIb laser product. Disconnected optical connectors might emit invisible optical radiation. Laser light, visible or invisible, can seriously injure eyes and even cause blindness.**

1. Disconnect the optical fiber(s) from the rear panel of the receiver. Immediately place protective caps over the bulkhead and fiber connector.
2. Disconnect the RF cables from the F-connectors.
3. Loosen the thumbscrew on the front panel of the module. CAUTION: Do not pull on the thumbscrew to remove the module. Pull on the handle that the thumbscrew goes through to remove the module.
4. Gently pull the module from the chassis using the handle that the thumbscrew goes through.

## ALARM DEFINITIONS

First push SET into LED display and set function.

Displayed Message	Alarm Status	System Response
000	No alarm	STA LED is green
001	Optical input low for Port 1	STA LED turns to red
002	Optical input high for Port 1	STA LED turns to red
003	Optical input low for Port 2	STA LED turns to red
004	Optical input high for Port 2	STA LED turns to red
005	Optical input low for Port 3	STA LED turns to red
006	Optical input high for Port 3	STA LED turns to red
007	Optical input low for Port 4	STA LED turns to red
008	Optical input high for Port 4	STA LED turns to red
009	Module temperature high	STA LED turns to red

## TROUBLESHOOTING

When the Status light is red, the operator can use the “▲”, “▼” and “SET” push button switch to check the alarms. DANGER/CAUTION: Do not remove the cover of the receiver or attempt to modify any part of it under any circumstances. Removing the cover could cause irreparable damage to the unit, and will void your warranty.

<b>Problem</b>	<b>Steps to Take</b>
Status (STA) LED is lit red.	<ol style="list-style-type: none"><li>1. Verify the optical input power range is 0 to -18dBm.</li><li>2. If all is normal, contact Olson Technology Inc. for further troubleshooting.</li></ol>
No RF power at the RF output port(s).	<ol style="list-style-type: none"><li>1. Clean the optical connector.</li><li>2. Verify the optical input power using an optical power meter.</li><li>3. Try to adjust the RF output through MGC function.</li><li>4. Measure RF power at output port.</li><li>5. If there is no RF power at the output port, the unit must be returned to the factory for service. Contact Olson Technology Inc. for more information.</li></ol>
RF output power is lower than the required amount.	<ol style="list-style-type: none"><li>1. Ensure all optical connectors are clean.</li><li>2. Verify the cable is terminated with the correct connector type.</li><li>3. Verify that the optical input power is within the normal range.</li><li>4. Try to adjust the RF output through MGC function.</li><li>5. Measure RF power at output port.</li><li>6. If the RF output power is still low, the unit must be returned to the factory for service. Contact Olson Technology Inc. for more information.</li></ol>

## SPECIFICATIONS

### Optical Characteristics (with SM 9/125 $\mu$ m Fiber)

	Min	Typ	Max	Units
Operating Wavelength	1260		1620	nm
Optical Input Power	-18		0	dBm
Optical Return Loss		-40		dB
Optical Input Ports		4		
Optical Connector	SC/APC			

### RF Output & Performance Characteristics

	Min	Typ	Max	Units
Frequency Range	5		200	MHZ
Band Flatness <sub>1</sub>	-0.75		+0.75	dB
RF Output Return Loss		18		dB
Output Level <sub>2</sub>		+45		dBmV
RF Attenuation Range	0		+20	dBm
Impedance		75		Ohms
CNR <sub>2</sub>	50			dB
IMD <sub>2</sub> <sub>3</sub>	-55			dB
IMD <sub>3</sub> <sub>3</sub>	-60			dB
RF Test Point	-20.75	-20	-19.25	dB
RF Connectors	F-female			

#### NOTES:

- 1) Band flatness is over a 5-200MHz range.
- 2) Received optical power of -7dBm with 16% OMI per channel, 0dB attenuation setting.
- 3) +45dBmV output, two-tone test,  $f_1=13\text{MHz}$ ,  $f_2=19\text{MHz}$ .
- 4) Non condensing.

### Electrical & Environmental Characteristics

	Min	Typ	Max	Units
Operating Temp. Range	0		+50	$^{\circ}\text{C}$
Storage Temp. Range	-40		+65	$^{\circ}\text{C}$
Relative Humidity <sub>4</sub>	5		95	%
P. S. Voltage		+24		$V_{\text{DC}}$
Power Consumption			10	W