



**OTPN-1000**

**PREMISE NODE**

**INDOOR BI-DIRECTIONAL NODE**

**INSTRUCTION MANUAL**

Phone: (209) 586-1022  
(800) 545-1022  
Fax: (209) 586-1026  
E-Mail: [salessupport@olsontech.com](mailto:salessupport@olsontech.com)  
[www.olsontech.com](http://www.olsontech.com)

## TABLE OF CONTENTS

INTRODUCTION	Page 4
INSTALLATION	Page 4
Installation/Environmental Considerations	Page 4
Optical Connectors and Cleaning	Page 5
Operational Setup - Receiver (Forward Path)	Page 6
Internal Test Points and Adjustments	Page 9
External Test Points	Page 9
ACCESSORIES	Page 9

## **SAFETY WARNINGS**

### **LASER RADIATION**



The OTPT-300 laser transmitter emits invisible radiation that can cause permanent eye damage. ***AVOID DIRECT EXPOSURE TO BEAM.***



Operate the transmitter only with the proper optical fiber installed in the transmitter optical connector. Power to the OTPN-1000 should be turned-off or preferably, disconnected whenever the optical connector cover is opened and there is no installed fiber (as when the fiber connector is being installed or removed from the transmitter connector).

***NEVER USE ANY OPTICAL INSTRUMENT TO VIEW THE OUTPUT OF THE LASER TRANSMITTER. "OPTICAL INSTRUMENT" INCLUDES MAGNIFYING GLASSES, ETC.***

***NEVER LOOK INTO THE OUTPUT OF THE LASER TRANSMITTER***

***NEVER LOOK INTO THE OUTPUT OF A FIBER CONNECTED TO A LASER TRANSMITTER.***

***NEVER LOOK INTO OR USE ANY OPTICAL INSTRUMENT TO VIEW THE DISTANT END OF A FIBER THAT MAY BE CONNECTED DIRECTLY OR VIA AN OPTICAL SPLIT, TO A TRANSMITTER THAT MAY BE OPERATING. THIS SPECIFICALLY APPLIES TO FIBERS THAT ARE TO BE CONNECTED TO RECEIVERS (SUCH AS THE OTPN-1000) OR OTHER DEVICES AT ANY DISTANCE FROM THE LASER TRANSMITTER.***

### **HIGH VOLTAGE**

The power supply section (bottom section) of the OTPN-1000 contains no user serviceable parts. There is exposed high voltage inside this section. Only factory service technicians should open the power supply section.

### **FIRE HAZARD**

The AC line input fuse is contained in the IEC 320 power input connector. This fuse is a 3AG, 0.5A, slow blow fuse. To avoid a risk of fire, this fuse should be replaced only with an identically rated fuse.

### **SHOCK HAZARD**

The OTPN-1000 is designed for indoor use only. Direct exposure to moisture must be avoided.

## INTRODUCTION

The Olson Technology Inc. OTPN-1000 is a high quality, cost effective, bi-directional CATV node designed around the latest optical receiver technology. It is designed to operate and meet full specifications with optical input levels ranging from -6dBm to +3dbm. The receive RF path includes provisions for plug-in equalizers to provide for sloped output response as well as plug-in pads to set the forward and reverse RF gains. The OTPN-1000 is available with two different band splits.

Model	Reverse Band	Forward Band
OTPN-1000	5-42 MHz	54-870 MHz
OTPN-1000-PAL	5-65 MHz	85-870 MHz

The OTPN-1000 does not come with a reverse laser transmitter. The OTPT-300 return transmitter module must be field-installed in the OTPN-1000 node.

The OTPN-1000 has a universal power supply that allows operation from 90 to 240 VAC @ 50 or 60 Hz. With an installed OTPT-300 Return Laser Transmitter, it consumes less than 23 watts of power. Positive cooling is provided by means of a small, high-MTBF fan, which may be replaced in the field without interrupting the operation of the node.

The OTPN-1000 has flanges on the bottom to allow mounting it to a flat surface. The available OTLL-RMKIT-2 will allow mounting up to three of these nodes in a standard 19" rack.

## INSTALLATION / ENVIRONMENTAL CONSIDERATIONS

The OTPN-1000 is specified to operate from -10°C to +55°C. It will probably not require an air-conditioned environment. It should be mounted in an adequately ventilated area. Like any other electronic equipment, it will probably have a longer life span if it is not operated at the upper limit of the temperature range. Installation in wet areas or areas of extremely high humidity should be avoided. Extremely dirty or dusty areas should be avoided if possible. Objects or debris should not be allowed to block the openings in the housing or the fan. The OTPN-1000 should not be installed in areas that are accessible to children.

The OTPN-1000 may be installed and operated in any position on a flat surface. The unit has four slots in the bottom plate to accommodate mounting hardware. The unit should be mounted by sliding over two screws and then tightening the other two screws. This is to accommodate current or future return lasers. If mounting requires a wood screw, use #6 or #8 (maximum) pan-head sheet metal screws. These are commonly available at hardware stores. If mounting with a machine screw (to tapped holes), use 6-32 pan-head screws. These specific screw sizes and head types must be used if the OTPN-1000 has an installed OTPT-300 return transmitter or if an OTPT-300 is likely to be installed later. This is due to limited clearance under the OTPT-300 that is above the mounting slots on one side. If the OTPN-1000 has an installed OTPT-300, mounting or dismounting the unit should not require the disconnection of the OTPT-300.

The fiber connector can be moved to the other end of the unit. Forward and reverse RF adjustments should be made before the OTPN-1000 is mounted to a rack mount kit.

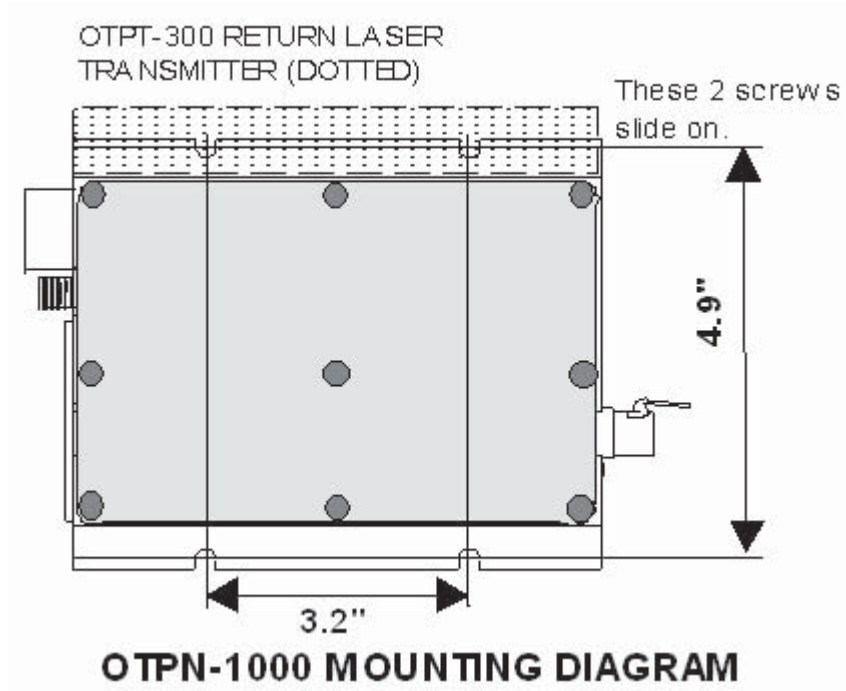

### OPTICAL CONNECTORS AND CLEANING

The standard optical connector is an SC/APC. In order to use FC/APC connectors, you must order a conversion kit, OTLL-SCFCKIT. The standard optical connector location is on the opposite side from the RF connector. The connector can be moved to the other side by swapping it with a cover plate. No tools are required for this operation.

The fiber ends can be damaged by the insertion of contaminated connectors. Some types of customer damage to connectors are not covered under warranty. Fiber connectors should never be left uncovered. Prepackaged alcohol wipes are the most convenient means of cleaning optical connectors. Clean alcohol and lint free wipes or swabs may also be used.

## OPERATIONAL SETUP – RECEIVER (FORWARD PATH)

The OTPN 1000 optical receiver as the last component in a specific optical link will provide carrier-to-noise performance and an RF output level that is dependent on several parameters. The RF input level to the source optical transmitter and the optical input level to the OTPN basically determine the link performance.

Both the laser modulation and the receiver output level are basically limited by total power. The RF input level to any optical transmitter is dependent on the number of channels being transmitted. As the number of carried channels is lowered, the RF input level to the transmitter can be raised. This results in increased RF levels at the OTPN receiver. This improves the carrier-to-noise ratio over the link. Links should be designed and transmitters should be set up using values that represent the maximum number of channels likely to be carried.

The receiver output power is also affected by the amount of equalization used. The use of a lower value equalizer will require reducing the output level as measured at the highest channel. This is because the attenuation of the lower channels is reduced.

The following chart assumes approximately 77 channels from 55 MHz to 550 MHz and digital loading from 550 MHz to 870 MHz at –6dB. The RF levels indicated are for an equivalent slope of 10dB with the actual levels measured at 547.25 MHz.

OPTICAL INPUT	RECEIVED POWER T.P.	FORWARD PAD VALUE	FORWARD EQUALIZER SLOPE/PART#	APPROX FWD T.P. LEVEL	APPROX RF OUTPUT LEVEL
-8dBm	.16V	0 dB	10dB/OLEQ8-13	+28 dBmV	+48 dBmV
-6dBm	.25V	4 dB	10dB/OLEQ8-13	+28 dBmV	+48 dBmV
-4dBm	.40V	8 dB	10dB/OLEQ8-13	+28 dBmV	+48 dBmV
-2dBm	.63V	12 dB	10dB/OLEQ8-13	+28 dBmV	+48 dBmV
0dBm	1.0V	16 dB	10dB/OLEQ8-13	+28 dBmV	+48 dBmV
+2dBm	1.58V	20 dB	10dB/OLEQ8-13	+28 dBmV	+48 dBmV

Although the node will operate at optical input levels as high as +3 dBm, there is little improvement in the C/N performance of the node at optical input levels above 0 dBm. For optimum distortion performance it is recommended that the optical input to the node be kept at or below 0 dBm. The Olson Technology model OTOA-xxx optical attenuators are ideal for this application. To lower the output level the value of the “Forward Pad” should be increased but a reduction below +45dBmV output at 547.25 MHz by this method is not recommended. If lower output is desired, the unit should be set for +45dBmV and an inline pad added to the RF output to reduce the output level. This will maintain optimum C/N performance. This will also reduce the return gain if an OTPT-300 return transmitter is attached.

Unlike many optical nodes, the OTPN-1000 is designed to give full output performance at a typical input of -8 dBm (-6 dBm minimum). The following chart shows the approximate C/N performance at various input levels and channel loading. This performance can vary considerably depending upon fiber and laser performance so it is presented as a design aid only.

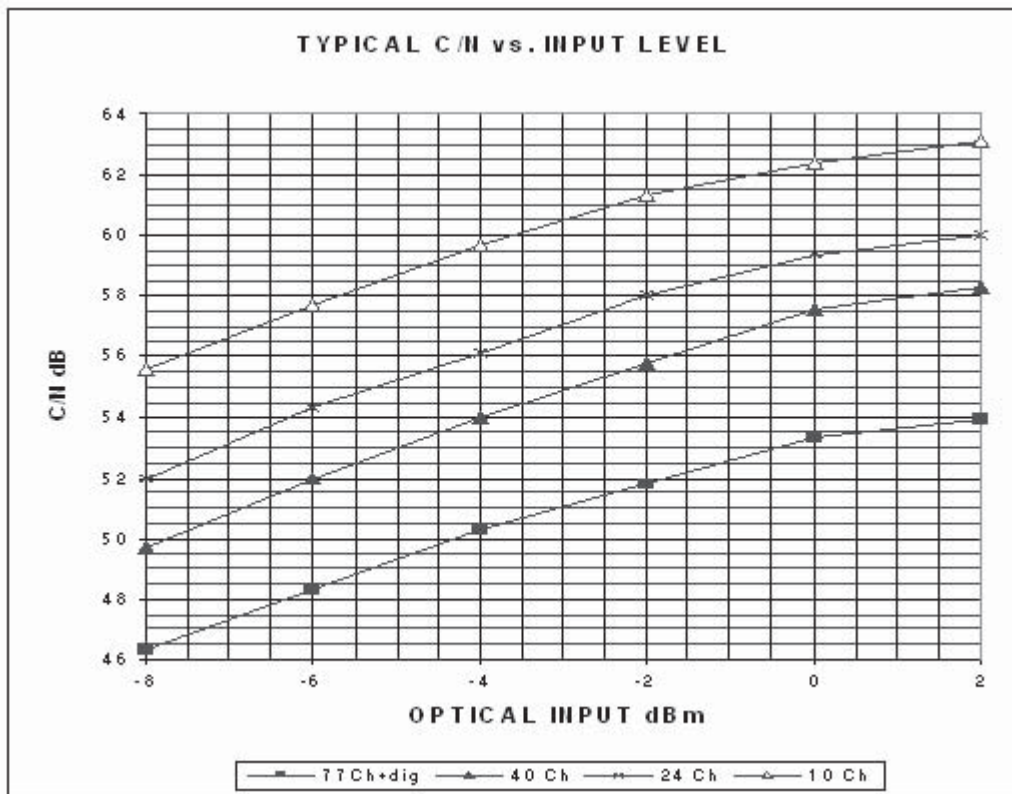

If a different 54-870 MHz slope value is desired than the provided 10 dB, different equalizer values are available. The following charts should help in determining your requirements.

FREQ RANGE	OLEQ8-8 SLOPE dB	OLEQ8-9 SLOPE dB	OLEQ8-10 SLOPE dB	OLEQ8-11 SLOPE dB	OLEQ8-12 SLOPE dB
54-870	6.22	6.99	7.77	8.55	9.32
54-550	3.89	4.37	4.86	5.35	5.83

FREQ RANGE	OLEQ8-13 SLOPE dB	OLEQ8-14 SLOPE dB	OLEQ8-15 SLOPE dB	OLEQ8-16 SLOPE dB	OLEQ8-17 SLOPE dB
54-870	10.1	10.88	11.66	12.43	13.21
54-550	6.32	6.8	7.29	7.78	8.26

FREQ RANGE	OLEQ8-18 SLOPE dB	OLEQ8-19 SLOPE dB	OLEQ8-20 SLOPE dB	OLEQ8-21 SLOPE dB	OLEQ8-22 SLOPE dB
54-870	13.99	14.76	15.54	16.32	17.09
54-550	8.75	9.23	9.72	10.21	10.69

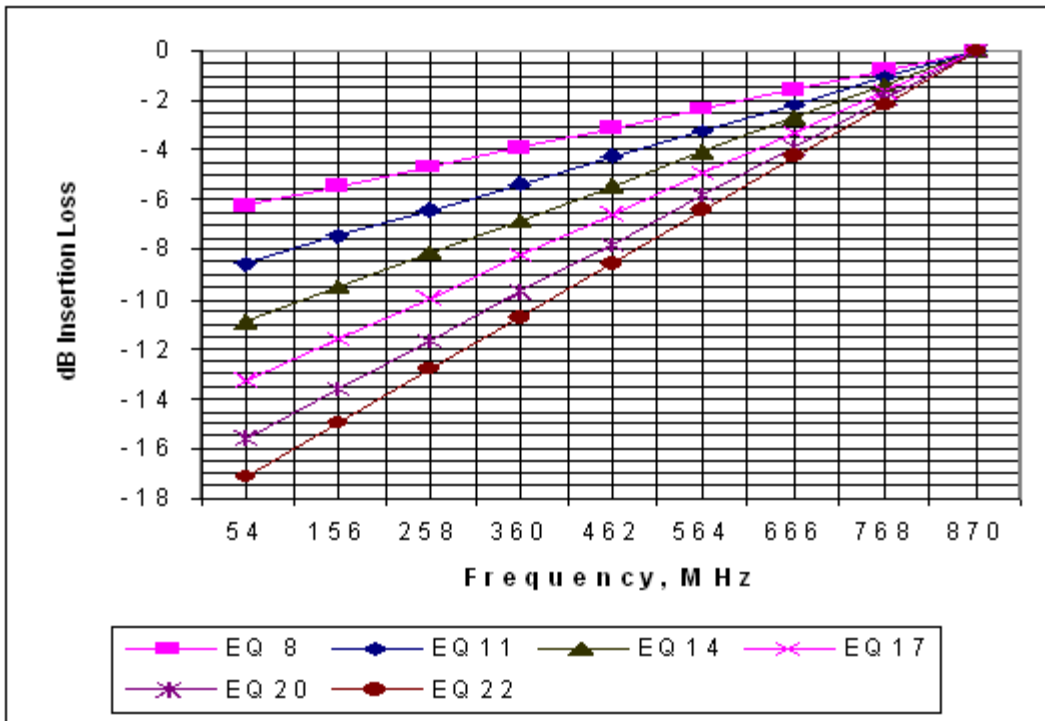
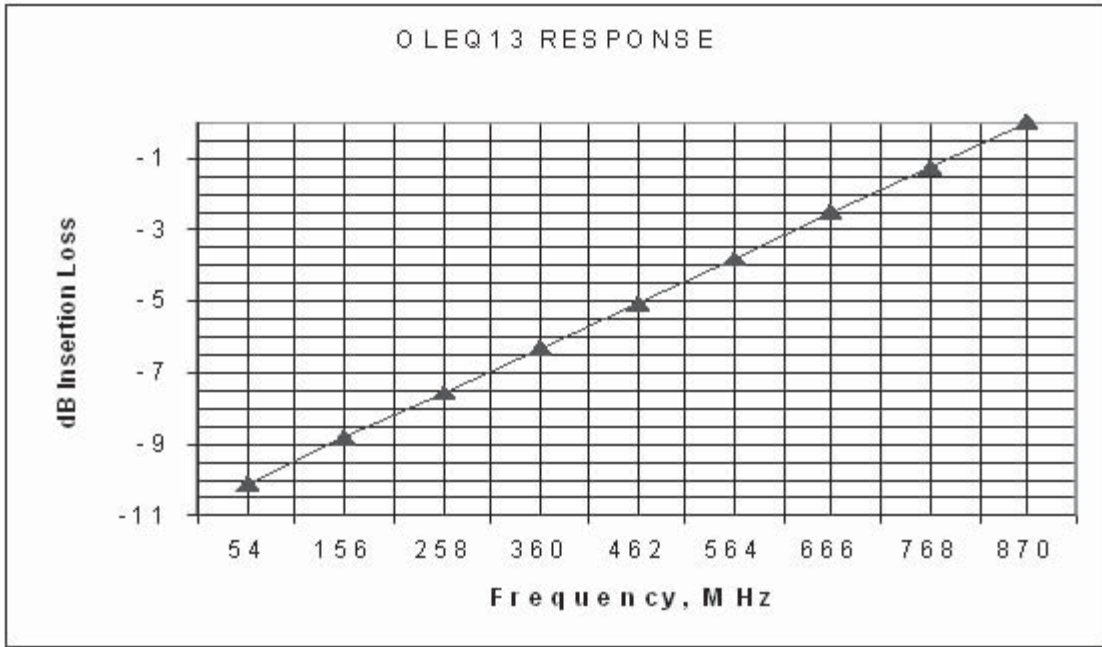

## INTERNAL TEST POINTS and ADJUSTMENTS

The OTPN-1000 receiver has an internal plug-in pad to allow the RF output level of the node to be adjusted. There is also a plug-in equalizer to compensate for cable slope. These adjustments are accessed by removing the 9 thumbscrews that hold the top cover on. The unit should not be operated for extended periods with the top cover removed. This is because of RF ingress and potential thermal problems due to unchanneled air flow. When replacing the top cover, be sure to firmly tighten all thumbscrews. RF ingress or oscillation can be caused by loose screws.

The locations of the internal adjustments are shown in the following diagram.

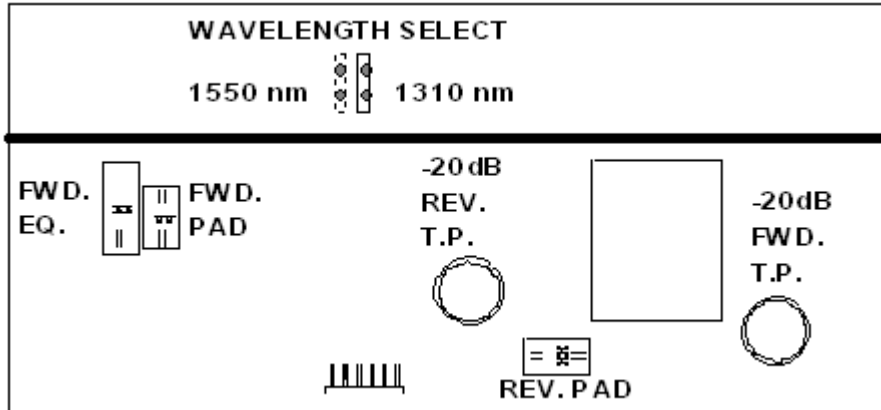

The forward adjustments are at the left. The forward test point is at the right. The reverse pad and test point in the center are used only when an OTPT-300 is attached. The wavelength select jumper is used to compensate the received power test point for the changes in responsivity of the photodiode with wavelength.

## EXTERNAL TEST POINTS

The OTPN-1000 has 1 external test point. It should be measured with a high impedance voltmeter. The received power test point is calibrated at 1V per mW @ 1310 nm. This test point is for long term monitoring purposes. The optical power should be measured with a power meter at the time of installation.

The input test point is calibrated at the factory at 1310 nm. The value at 1550 nm may be off by 15% due to diode variations. The input test point reading will be considerably off if the input wavelength is 1550 nm and the internal jumper has not been changed.

## ACCESSORIES

MODEL	DESCRIPTION
OTPT-300	Reverse DFB Laser Transmitter
OTPT-300-FP	Reverse FP Laser Transmitter
OLEQ8xx	Single Forward Equalizer
OLEQ8-KIT-x	Forward Equalizer Kits
PAD-xxx	Single Pad (Forward or Reverse)
PAD-KIT-x	Pad Kits (Forward or Reverse)
OTLL-SCFCKIT	SC/APC to FC/APC Optical Connector Adaptor
OTLL-RMKIT-2	Rack Mount Kit (Holds 3 OTPN-1000's)
OTOA-xxxx	Optical Attenuators
OTLL-FANKIT	Replacement Fan Assembly



**OTPT-300A SERIES**

**LOW COST INDOOR  
RETURN LASER TRANSMITTER**

**INSTRUCTION MANUAL**

Phone: (209) 586-1022

(800) 545-1022

Fax: (209) 586-1026

E-Mail: [salesupport@olsontech.com](mailto:salesupport@olsontech.com)

[www.olsontech.com](http://www.olsontech.com)

## TABLE OF CONTENTS

SPECIFICATIONS	Page 3
SAFETY WARNINGS	Page 4
INTRODUCTION	Page 5
INSTALLATION	Page 5
Environmental Considerations	Page 5
Optical Connectors and Cleaning	Page 5
Installation	Page 6
Internal Controls	Page 7
External Controls and Test Points	Page 7
ACCESSORIES	Page 8

### OTPT-304A and 305A - Specifications For Use With DFB Laser

Reverse Frequency Range.....	5MHz to 42MHz, or 5MHz to 65MHz
Reverse Frequency Response.....	±1.0dB 5MHz to 42MHz or 5MHz to 65MHz
Ext. Aux. RF Input Response.....	5-300MHz +/- 1.0dB
Input Return Loss.....	>16dB @ 5MHz to 42MHz or 5MHz to 65MHz
Return Laser Output Power.....	3.0mW +0.5mW @ 1310 and 2.0mW +0.5mW @ 1550
Return Path NPR.....	>15dB over 41dB NPR measured with 10dB fiber and Olson High Sensitivity Return Band Receiver
NPR 41dB Threshold.....	-57dBmV/Hz
Test Points.....	Laser Power 1V/mW Laser Current 1V/50mA
Optical Connector.....	SC/APC or Optional FC/APC
Weight.....	0.5 lbs.
Dimensions.....	2 7/16" H x 11/16" W x 7 1/16" D - 6.25cm H x 1.8cm W x 18cm D

### OTPT-302A and 303A - Specifications For Use With FP Laser

Reverse Frequency Range.....	5MHz to 42MHz, or 5MHz to 65MHz
Reverse Frequency Response.....	±1.0dB 5MHz to 42MHz or 5MHz to 65MHz
Ext. Aux. RF Input Response.....	5-300MHz +/- 1.0dB
Input Return Loss.....	>16dB @ 5MHz to 42MHz or 5MHz to 65MHz
Return Laser Output Power.....	1.6mW +0.5mW @ 1310nm Non-Isolated or a 2.0mW +0.5mW @ 1310nm Isolated
Return Path NPR.....	>15dB over 37dB NPR measured with 6dB fiber and Olson High Sensitivity Return Band Receiver
NPR 37dB Threshold.....	-57dBmV/Hz
Test Points.....	Laser Power 1V/mW Laser Current 1V/50mA
Optical Connector.....	SC/APC or Optional FC/APC
Weight.....	0.5 lbs.
Dimensions.....	2 7/16" H x 11/16" W x 7 1/16" D - 6.25cm H x 1.8cm W x 18cm D

### OTPT-347A - 361A - Specifications For Use With CWDM Laser

Reverse Frequency Range.....	5MHz to 42MHz, or 5MHz to 65MHz
Reverse Frequency Response.....	±1.0dB 5MHz to 42MHz or 5MHz to 65MHz
Ext. Aux. RF Input Response.....	5-300MHz +/- 1.0dB
Input Return Loss.....	>16dB @ 5MHz to 42MHz or 5MHz to 65MHz
Return Laser Output Power.....	2.0mW +0.5mW @ 1470-1610nm
Return Path NPR.....	>15dB over 41dB NPR measured with 10dB fiber and Olson High Sensitivity Return Band Receiver
NPR 41dB Threshold.....	-57dBmV/Hz
Test Points.....	Laser Power 1V/mW Laser Current 1V/50mA
Optical Connector.....	SC/APC or Optional FC/APC
Weight.....	0.5 lbs.
Dimensions.....	2 7/16" H x 11/16" W x 7 1/16" D - 6.25cm H x 1.8cm W x 18cm D

## SAFETY WARNINGS

### LASER RADIATION



The OTPT-300A Series laser transmitter emits invisible radiation that can cause permanent eye damage. ***AVOID DIRECT EXPOSURE TO BEAM.*** Operate the transmitter only with the proper optical fiber installed in the transmitter optical connector. Power to the OTPT-300A Series



should be turned-off or preferably, disconnected whenever the optical connector cover is opened and there is no installed fiber (as when the fiber connector is being installed or removed from the transmitter connector).

***NEVER USE ANY OPTICAL INSTRUMENT TO VIEW THE OUTPUT OF THE LASER TRANSMITTER. "OPTICAL INSTRUMENT" INCLUDES MAGNIFYING GLASSES, etc.***

***NEVER LOOK INTO THE OUTPUT OF THE LASER TRANSMITTER.  
NEVER LOOK INTO THE OUTPUT OF A FIBER CONNECTED TO A LASER TRANSMITTER.***

***NEVER LOOK INTO OR USE ANY OPTICAL INSTRUMENT TO VIEW THE DISTANT END OF A FIBER THAT MAY BE CONNECTED DIRECTLY OR VIA AN OPTICAL SPLIT, TO A TRANSMITTER THAT MAY BE OPERATING. THIS SPECIFICALLY APPLIES TO FIBERS THAT ARE TO BE CONNECTED TO RECEIVERS (SUCH AS THE OTOR-300) OR OTHER DEVICES AT ANY DISTANCE FROM THE LASER TRANSMITTER.***

### HIGH VOLTAGE

The power supply section (bottom section) of the OTPN-1000 contains no user serviceable parts. There is exposed high voltage inside this section. Only factory service technicians should open the power supply section.

### FIRE HAZARD

The AC line input fuse is contained in the OTPN-1000 IEC power input connector. This fuse is a 3AG, 0.5A, slow blow fuse. To avoid a risk of fire, this fuse should be replaced only with an identically rated fuse.

### SHOCK HAZARD

The OTPT-300A Series is designed for indoor use only. Direct exposure to moisture must be avoided.

## INTRODUCTION

The Olson Technology OTPT-300A Series is a cost effective field installable return laser transmitter with an RF passband of 5 to 300MHz. The unit has a DFB laser with 3mW output (+4.8dBm), an Non-Isolated FP laser with 1.6mW output (+2.0dBm), an Isolated FP laser with 2.0mW output (+3.0dBm), or a CWDM laser with a 2.0mW output (+3.0dBm). This transmitter is intended only for indoor applications. This transmitter must be mounted to an OTPN-1000. It will not function as a stand-alone device. The diplex filter, test point, return OMI pad, and AC power supply are part of the OTPN-1000. The actual return passband is determined by the diplex filter in the OTPN-1000. The OTPT-300A Series is equipped with an auxiliary external RF input for 5-300MHz operation that can be used in upstream video or block converter applications.

## ENVIRONMENTAL CONSIDERATIONS

The OTPT is specified to operate from -10°C to +55°C. It will probably not require an air-conditioned environment. It should be mounted in an adequately ventilated area. Like any other electronic equipment, it will probably have a longer life span if it is not operated at the upper limit of the temperature range. Installation in wet areas or areas of extremely high humidity should be avoided. Extremely dirty or dusty areas should be avoided if possible. Objects or debris should not be allowed to block the openings in the OTPN-1000 housing or fan. The unit should not be installed in areas that are accessible to children.

## OPTICAL CONNECTORS AND CLEANING

The standard optical connector is an SC/APC. In order to use FC/APC connectors, you must order a conversion kit, OTLL-SCFCKIT. The standard optical connector location is on the opposite side from the RF connector. The connector can be moved to the other side by swapping it with a cover plate. Only a screwdriver is required for either operation.

Either of these operations **must** be done **before** the OTPT is mounted to the OTPN-1000. Failure to replace all of the OTPT cover screws can cause RF ingress problems.

The fiber ends can be damaged by the insertion of contaminated connectors. Some types of customer damage to connectors are **not** covered under warranty. Fiber connectors should never be left uncovered. Prepackaged alcohol wipes are the most convenient means of cleaning optical connectors. Clean alcohol and lint free wipes or swabs may also be used.

## INSTALLATION

1. If the OTPN-1000 is operational, REMOVE power from the OTPN-1000 before proceeding.
2. Remove the cover plate on the side of the OTPN-1000. Save the plate and screws in order to eliminate RF ingress if the OTPT should ever be removed.

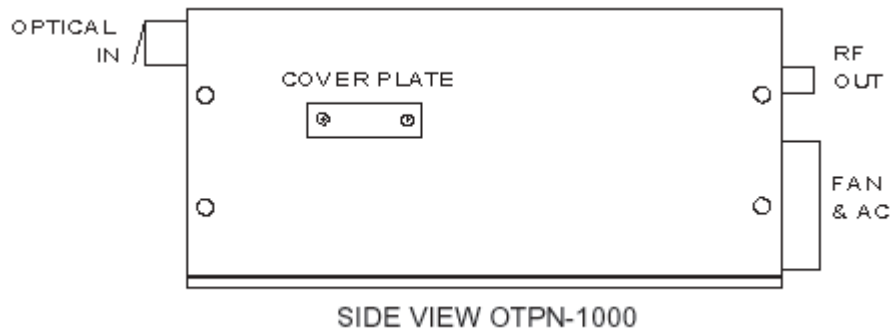

3. Carefully push the OTPT onto the side of the OTPN-1000. Clean the side of the OTPN-1000 with alcohol if required. No heat sink gasket or compound is required between the OTPT and the OTPN-1000.
4. Firmly screw in the four mounting screws provided. If the original screws are missing, use 4-40x7/8" or 4-40x1" screws with lockwashers.

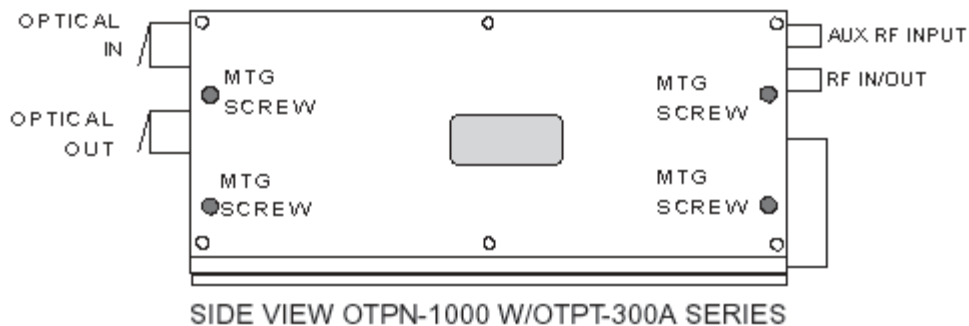

5. Apply power to the OTPN-1000.
6. Measure the OTPT output power with an optical power meter and record the result.
7. Remove power from the OTPN-1000.
8. Clean the return fiber per your system standards and insert into the optical output connector.
9. Apply power to the OTPN-1000.
10. Measure the OTPT laser power and laser current test points and record the results.
12. Remove the top cover from the OTPN-1000.

12. The specification for the return band transmitter RF input level is -57dBmV/Hz (measured at the OTPN-1000 R.F. port). This value operates the system at the NPR threshold. The OTPN-1000 has a plug-in attenuator in the reverse path. Also included is a -20dB test point in the return path. Note that the -20dB test point is before the plug-in attenuator. The single carrier equivalent of -57dBmV/Hz is +9dBmV. The pad must be selected to set the return carrier level to +9dBmV actual, after the attenuator. With a test carrier present at the port, measure its level at the reverse -20dB test point. Use the actual level (test point +20dB) measured, to determine what value of attenuator must be used to provide +9dBmV after the attenuator.

EXAMPLE: Test Point reading of +5dBmV plus -20dB test point equals +25dBmV minus +9dBmV equals 16dB pad required.

13. Firmly replace all OTPN-1000 top cover screws. Failure to do so can result in cooling, RF radiation, or RF ingress problems.

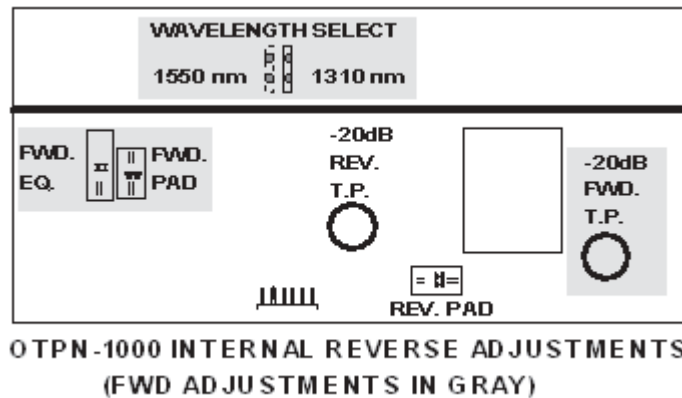

### AUXILIARY RF INPUT

When using the OTPT in the external auxiliary RF input mode (5-300MHz) the level will be +6.0dBmV per carrier and has no input attenuator or test point.

### INTERNAL CONTROLS

Switching from internal duplex (5-42MHz) operation to external RF input (5-300MHz) is achieved by an internal jumper J1 on the OTPT printed circuit board.

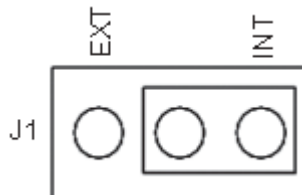

There is no user adjustable internal laser power adjustment. Any change to the laser power will result in poorer modulation characteristics and reduced link performance.

The return pad and return test point are located inside the OTPN-1000 as shown above.

### EXTERNAL CONTROLS AND TEST POINTS

The OTPT has 2 external DC test points. One reads laser current at 1V per 50mA. A typical laser current of 25mA would read 0.5V at this test point. The laser power test point is 1V per mW. This is for historical tracking. The optical power meter is a much more accurate means of measuring power. Both of these test points should be measured with a high impedance voltmeter.

## ACCESSORIES

MODEL	DESCRIPTION
PAD-xxx	Single Pad (Forward or Reverse)
PAD-KIT-x	Pad Kits (Forward or Reverse)
OTLL-SCFCKIT	SC/APC to FC/APC Optical Connector Adaptor
OTLL-RMKIT-2	Rack Mount Kit (Holds 3 OTPN-1000's)
OTOA-1000	Optical Attenuator
OTLL-FANKIT	OTPN-1000 Replacement Fan Assembly

## RELATED OLSON TECHNOLOGY PRODUCTS

MODEL	DESCRIPTION
OTPN-1000	Receive only wideband indoor node 5-42 MHz return band.
OTPN-1000-PAL	Receive only wideband indoor node 5-65 MHz return band.
OTOR-300	Indoor return band optical receiver.

## OTPT MODELS

OT MODEL #	OT PART #	RETURN LASER
OTPT-302A	037-010471	1.6mw 1310nm FP
OTPT-303A	037-020471	2mw 1310nm ISO FP
OTPT-304A	037-000471	3mw 1310nm DFB
OTPT-305A	037-030471	2mw 1550nm DFB
OTPT-347A	037-040471	CWDM 2mw 1470nm DFB
OTPT-349A	037-050471	CWDM 2mw 1490nm DFB
OTPT-351A	037-060471	CWDM 2mw 1510nm DFB
OTPT-353A	037-070471	CWDM 2mw 1530nm DFB
OTPT-355A	037-080471	CWDM 2mw 1550nm DFB
OTPT-357A	037-090471	CWDM 2mw 1570nm DFB
OTPT-359A	037-100471	CWDM 2mw 1590nm DFB
OTPT-361A	037-110471	CWDM 2mw 1610nm DFB