

MetroNode OTMN-II

4-OUTPUT COMPACT, MODULAR, SCALEABLE FIBER DEEP FTTC OPTICAL NODE

Features / Benefits

- Flagship Model of the OT “Metro Node” family. Field-Proven, 1000’s deployed worldwide
- High Performance, High Output, Economical, Low Power Dissipation, Two-Way Capable
- Advanced GaAs device technology provides Excellent RF Performance to 870MHz or optional 1GHz
- Quad RF Amplifier Module provides Four (4) +50dBmV high level RF Output Ports
- Interstage Slope and RF Input/Output controlled via internal Plug-in EQ’s and Plug-in attenuator Pads
- Choice of frequency Diplexer splits: 42/54MHz -or- 65/85MHz for NTSC, PAL & CENELEC use
- +50dBmV High RF Output Levels maintained over Wide Optical Input Range: +2dBm to -4dBm
- Multiple Redundancy & Segmentation Configurations via dual Receiver &/or dual Transmitter Options
- Choice of DFB & CWDM Return Lasers; High Performance Return Path: >15dB over 41dB NPR
- Power Factor Corrected Switching Power Supply accepts 40-90V_{AC}; Overvoltage Protection to 140V_{AC}
- Optional High Sensitivity Receiver (-8dBm to -3dBm)
- Optional Powering via 5th Dedicated AC Input Port; No Power Inserter Required at the node
- Optional use of 5th Power Port for Return Path Output/Input
- Optional NMS-Standard Status Monitoring & Control module
- Integrated User-Friendly Fiber Management Tray to accommodate optical fiber and splices



The **OLSON TECHNOLOGY, INC. MetroNode Model OTMN-II** is a high performance, four output CATV optical node, offering the capability of greater than +50dBmV output levels. This node benefits the system operator by extending overall path length, maximizing equipment usage and reducing the number of network elements. Full RF output can be maintained with an optical input as low as -4dBm. With system performance to 870MHz (or optional 1GHz), the **MetroNode OTMN-II** provides the ideal platform for support of the evolving technologies and services in today’s advanced HFC and PON networks. **MetroNode OTMN-II** offers protection configurations which are ideal for critical analog and digital transmission, telephony and data services. Utilizing extensive modular design with easy in-field replacement, the **MetroNode OTMN-II** can meet any advanced broadband network requirement.

MetroNode OTMN-II

MetroNode OTMN-II is an appropriate final active component solution in any broadband CATV system. Configured in a rugged, weatherproof, minimal footprint, finned cast-aluminum housing (with or without optional powdercoating protection), the unit is ideal for strand or pedestal mounting. The node operates over a wide temperature range and accepts cable powering from 40 to 90V_{AC} with over voltage protection to 140V_{AC}. Cable and fiber entry ports accept standard 5/8-24 threaded CATV connectors. Internal RF connections are made with 75 Ohm mini-type SMB connectors. RF test connections are male type-G and mate with standard adapters. The unit also has a user and fiber-friendly fiber-organizing tray with large spools for management of input and output optical fibers and a special unit to accommodate optical splices.

Redundant optical forward receiver and return transmitter capability in the **MetroNode OTMN-II** assures increased network reliability. Careful design of the receiver circuit allows for a variety of channel loading up to 110 NTSC, 64 PAL B/G, D or 42 CENELEC channels (as per EN50083) or a combination of analog and digital signals. Each receiver utilizes a PIN optical receiver and a low-noise preamplifier to assure optimum carrier-to-noise performance. Setup of the receiver is facilitated by an internal optical test point circuit. Level control and equalization of forward and reverse paths are made by use of plug-in pads and equalizers. Forward and reverse -20dB test points are provided and DC test points are provided for received optical power input level and return laser transmitter output power. The **MetroNode OTMN-II** also includes provisions for an optional NMS-Standards-Compliant transponder for network monitoring and provisioning of the unit.

The optical input section has three configuration options to meet any type of operating requirements. Option 0 is a single RF input from a single optical receiver unit. The signal passes through the options board to the RF amplifier section. Option 1 provides for automatic switching of redundant RF signals from the output of two optical receivers. The plug-in board includes all detection circuitry and the RF switch. The output of the RF switch passes to the RF amplifier section of the node. Option 2 is used for split band operations, where the received signals from the two optical receivers are two different portions of the RF spectrum. This option allows node combining of standard RF signals and QAM signals or VOD signals. Both signal paths include filtering for optimum combining. The split may be at any frequency from 100MHz to 650MHz. Option 3 is a single RF input from a special High Sensitivity (-3dBm to -8dBm) optical receiver unit.

Utilizing the latest amplifier technology, including GaAs devices, **MetroNode OTMN-II** produces four (4) RF outputs, each capable of delivering +50dBmV with excellent specifications, into four (4) identical bi-directional coaxial ports. Each port has a forward (downstream) passband of 54-870 MHz (or optional 1GHz) and a reverse (upstream) passband of 5-42 MHz. Optional passband frequencies of 85-870MHz (or optional 1GHz) and 5-65MHz are also available. All four bi-directional ports are capable of passing power into or out of the node. Separate jumper plugs configure each of the ports. A unique feature of the unit allows the jumper plugs to be replaced by automotive-type ATC fuses. A fifth port designated as a power port can be optionally configured to also serve as an RF port for return band signals into or out of the housing. This port is also fused if required.

MetroNode OTMN-II has independent outputs which offer a wide choice of configurations. The forward path receiver modules feature a wide optical input range of +2dBm to -4dBm with either 1310nm or 1550nm signals. In addition, the node maintains its full +50dBmV RF output capability at all optical input levels throughout that range, allowing system operators to operate them at maximum capability in fiber deep applications. The node can be configured for high level bridger outputs or for direct output to high density distribution systems. The unit's high output level offers the ability to optimize the coaxial plant distribution from a single node and contributes to reduced amplifier cascades, making medium to high density systems more cost effective. The performance and output levels of the node also allow it to be easily integrated into any current system architecture.

The upstream return path system may be configured for transmitter redundant ring or 1x2 node split operation using a wide array of 1310nm DFB and 1550nm DFB & CWDM Return Laser options

MetroNode OTMN-II

SPECIFICATIONS

| | |
|--|---|
| Optical Input Range (Standard)..... | -4dBm to +2dBm |
| Optical Input Range (Optional High Sensitivity)..... | -8dBm to -3dBm |
| Forward Frequency Range..... | 54MHz to 870MHz or 85MHz to 870MHz (optional 1GHz top end) |
| Reverse Frequency Range..... | 5MHz to 42MHz or 5MHz to 65MHz |
| Forward Frequency Response..... | <±0.75dB to 870MHz, ±1.0dB from 54MHz to 1GHz |
| Reverse Frequency Response..... | <±0.75dB 5MHz to 42MHz or 5MHz to 65MHz |
| Output Level (Forward)..... | +50dBmV @ 550MHz (Each of four outputs) With -1dBm optical input, 10dB slope to 870MHz, and Transmitter OMI @ 3.2%. (1GHz option is 12dB slope and +48dBmV output) |
| Distortion..... | >62dB CSO/CTB @ above output and +3dBm optical input. Carrier loading (77 channels) to 550MHz. Simulated data loading @ -6dB from 550MHz to 870MHz (or optional 1GHz). |
| Carrier to Noise..... | >53dB @ -1dBm optical or greater Carrier loading (77 channels) to 550MHz |
| In/Out Return Loss..... | >16dB - All ports 1 through 4 (as applicable) from 54-870MHz >14dB - All ports 1 through 4 (as applicable) from 54MHz-1GHz Port 5 (power port) >15dB to 65MHz with optional return port configuration |
| Return Laser Output Power(s)..... | 1.5, 2.0, 2.5 and 3.0mW ±0.5mW |
| Return Path NPR..... | Range over 41dB NPR is >15dB measured with 10dB of fiber and with (With DFB Return Laser & OTLP-OR-300 return band receiver.) |
| Return Path NPR..... | Range over 41dB NPR is as follows: (With DFB Return Laser) >13dB measured with 10dB of fiber as above and both bands moving together. |
| Return Path NPR Threshold..... | < -57dBmV/Hz |
| Operating Temperature Range..... | -40°C to +65°C |
| Gain Variation vs. Temperature..... | <±1dB typical } FORWARD <±1.5dB Max <±1.8dB REVERSE |
| AC Power Requirements..... | 76.5 Watts @ 60 V _{AC} @ 50-60Hz; (45V _{AC} to 90V _{AC}). Will withstand overvoltage to 140V _{AC} |
| Internal Test Points..... | See unit diagram for functional description and location |
| Hum Modulation..... | >60dB @ 15 Amps AC current from any one port 7MHz to 25MHz >65dB @ 15 Amps AC current from any one port 25MHz to 870MHz |
| Size..... | 11-1/2"W x 8-1/4"D x 9"H |



Quality / Engineering / Innovation

OTMN-II MODEL NUMBER CONFIGURATOR

| OTMN - | N - | XYZ - | AB - | CD - | EF | /OPT | |
|---|--|---|---|---|---|--|---------------|
| | | # Outputs/Diplexer | Return Transmitter(s) | Receiver(s) | 5th Port Return | Status Monitoring | Other Options |
| | 0: 4-Output; 42/54MHz 1: 4-Output; 65/85MHz | 000: No Return Transmitter X = 0 (Single Transmitter) X = 1 (Dual Transmitter) X = 2 (1 Tx; Status Monitoring TR) X = 3 (Dual Tx, Split Feeder Return) X = 4 (Dual Tx Capable, Split Feeder Return, Field Upgradeable. Ships with one Tx only) | 00: Single Rx (std) 01: Dual Rx w/ ABS 02: Split Band Dual Rx (contact OT) 03: High Sensitivity Rx | 00: No 5th Port Return 01: 5th Port Return | 00: Without Status 01: With Status | IP: Powdercoating Other options as required (Contact Factory) | |
| * ACCESSORIES REQUIRED for OPERATION: | | | | | | | |
| 1) Plug-In Equalizers (23 Values. Specify 0dB to 22dB in 1.0dB increments.) - Model# 9508xxL (Individual 870MHz Equalizer; xx = value 00 to 22) - Model# 950800K (15 EQ's 870MHz Equalizer Kit; values 08 to 22) | | | | | | | |
| 2) Plug-In Attenuators (19 Values. Specify 0dB to 18 dB in 1.0dB increments.) - Model# 9518xxL (Individual Attenuator Pads; xx = value 00 to 18) - Model# 951800K (19 Pads Attenuator Kit; values 00 to 18) | | | | | | | |
| * Typical OTMN-II node shipped with 10dB slope & +50dBmV output/port @ -1dBm. Optional Pad & EQ accessories needed for different performance values. | | | | | | | |

Block Diagram

OTMN-II Diagram

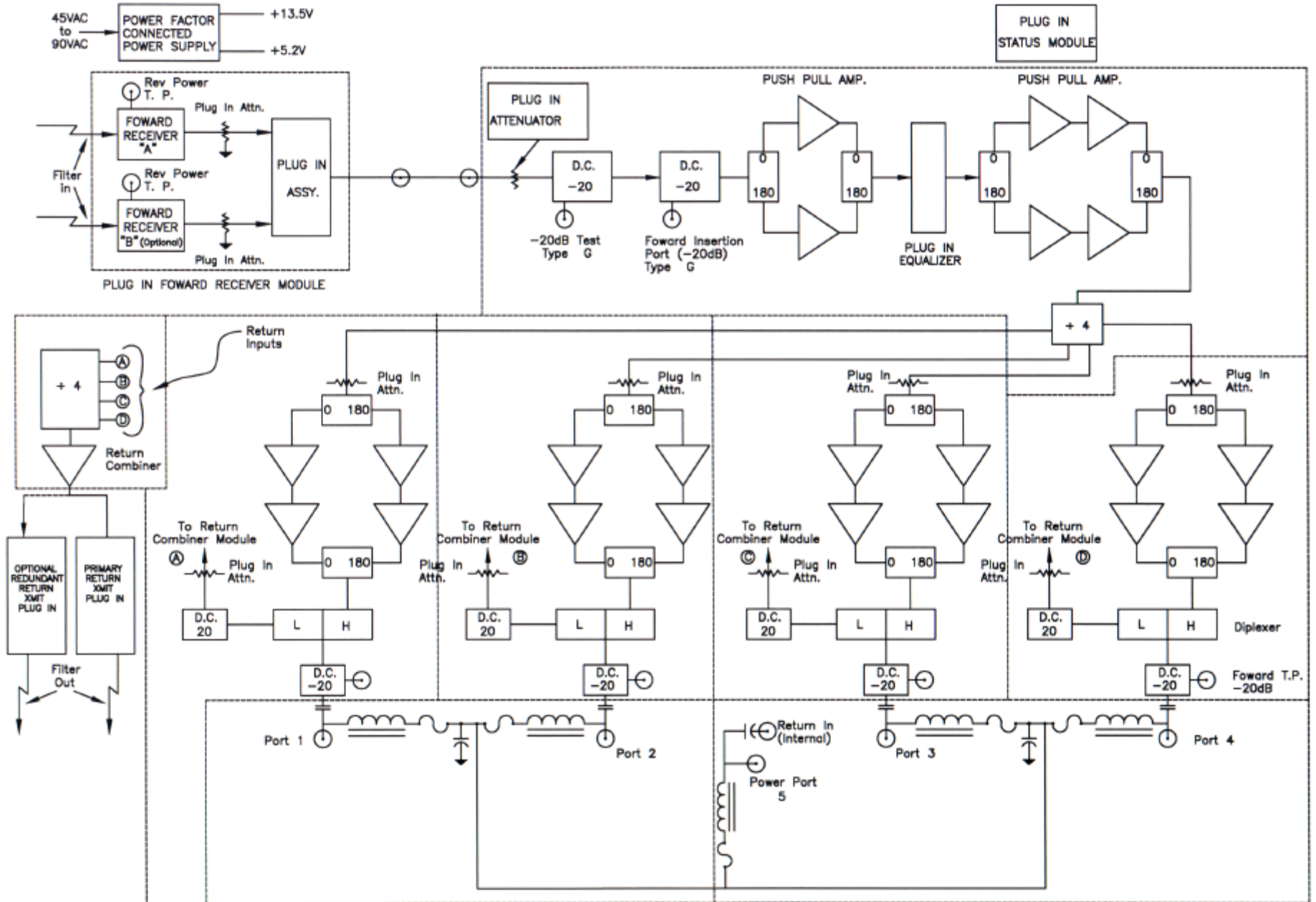

OTMN-II
FORWARD RECEIVER DIAGRAM

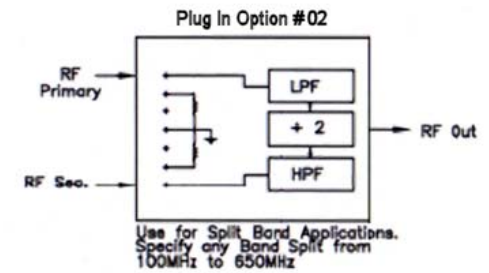
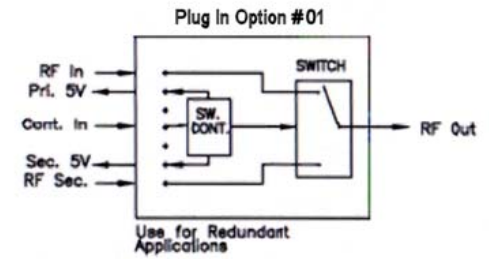
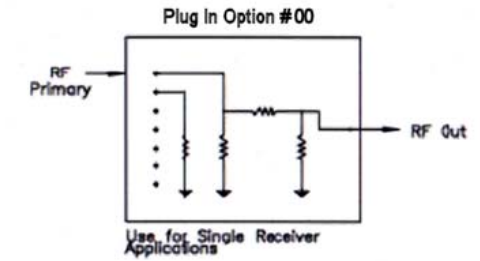
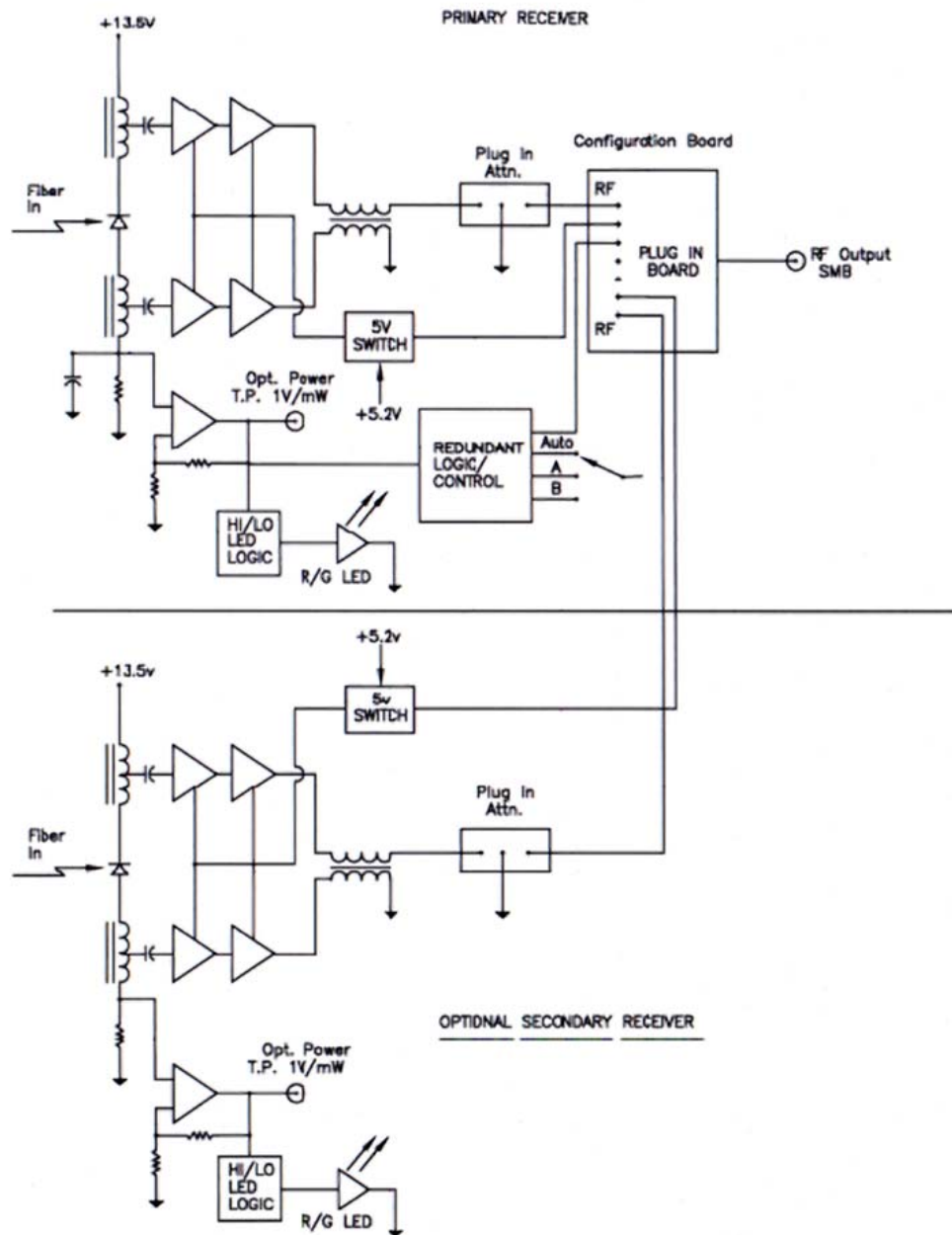

OTMN-II
RETURN LASER TRANSMITTER

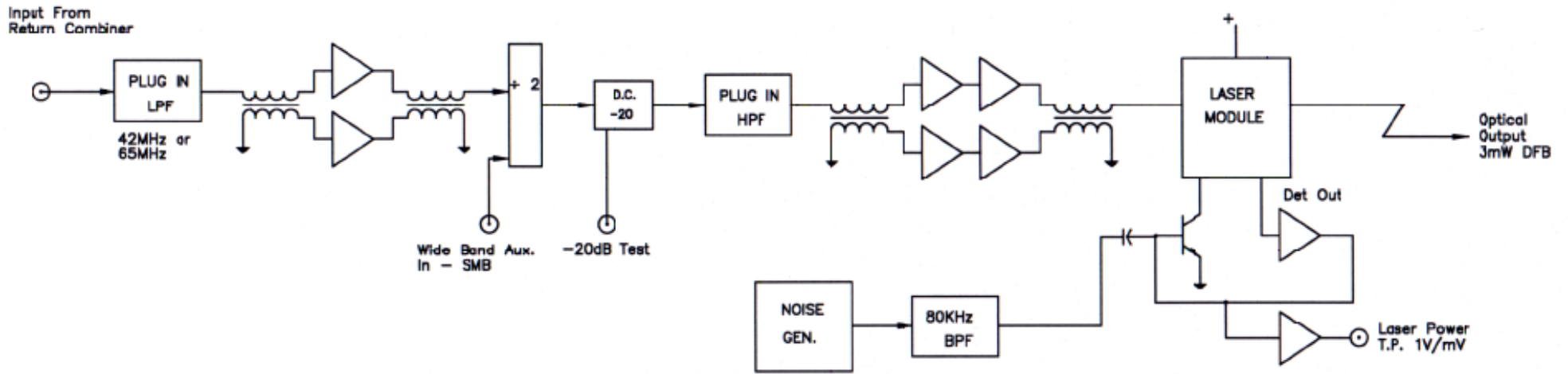

RETURN COMBINER OPTIONS

Option #1 - For Single Return Xmit. Applications

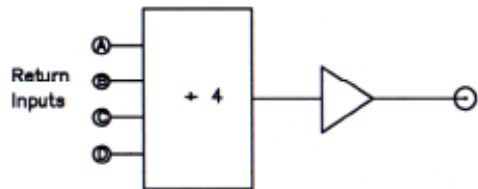

Option #2 - For Dual Return Xmit. Applications

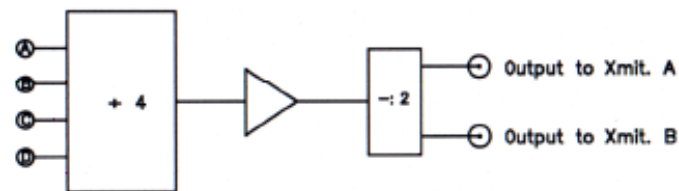

Option #3 - For Split Return

